

# JVC

## SERVICE MANUAL

### MICRO COMPONENT SYSTEM

## UX-P58V

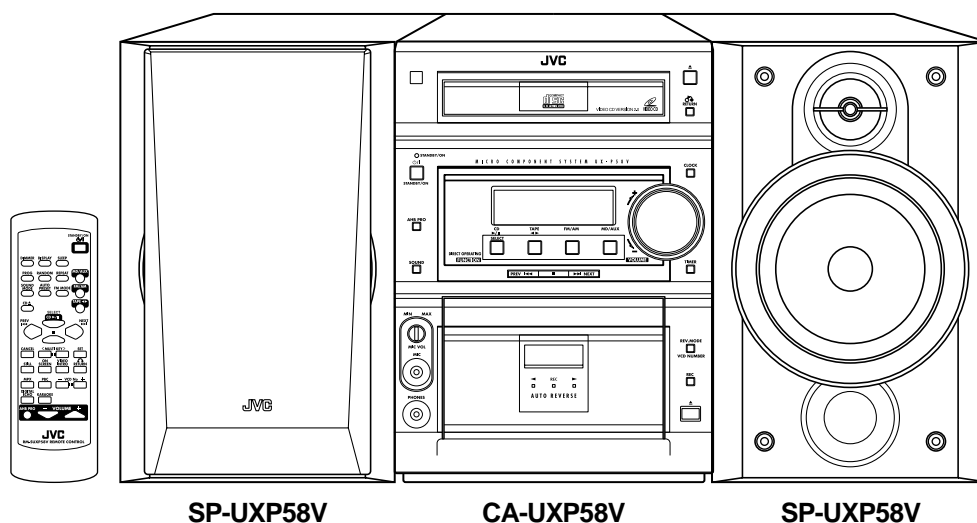

#### Area Suffix

US	-----	Singapore
UN	-----	Asean
UB	-----	Hong Kong

### Contents

Safety precautions	-----	1-2	Flow of functional operation	
Important for laser products	-----	1-3	until TOC read	----- 1-20
Preventing static electricity	-----	1-4	Maintenance of laser pickup	----- 1-21
Disassembly method	-----	1-5	Replacement of laser pickup	----- 1-21
Adjustment method	-----	1-16	Description of major ICs	----- 1-22~35

## Safety Precautions

1. This design of this product contains special hardware and many circuits and components specially for safety purposes. For continued protection, no changes should be made to the original design unless authorized in writing by the manufacturer. Replacement parts must be identical to those used in the original circuits. Services should be performed by qualified personnel only.
2. Alterations of the design or circuitry of the product should not be made. Any design alterations of the product should not be made. Any design alterations or additions will void the manufacturer's warranty and will further relieve the manufacture of responsibility for personal injury or property damage resulting therefrom.
3. Many electrical and mechanical parts in the products have special safety-related characteristics. These characteristics are often not evident from visual inspection nor can the protection afforded by them necessarily be obtained by using replacement components rated for higher voltage, wattage, etc. Replacement parts which have these special safety characteristics are identified in the Parts List of Service Manual. Electrical components having such features are identified by shading on the schematics and by ( $\triangle$ ) on the Parts List in the Service Manual. The use of a substitute replacement which does not have the same safety characteristics as the recommended replacement parts shown in the Parts List of Service Manual may create shock, fire, or other hazards.
4. The leads in the products are routed and dressed with ties, clamps, tubings, barriers and the like to be separated from live parts, high temperature parts, moving parts and/or sharp edges for the prevention of electric shock and fire hazard. When service is required, the original lead routing and dress should be observed, and it should be confirmed that they have been returned to normal, after re-assembling.

### 5. Leakage current check (Electrical shock hazard testing)

After re-assembling the product, always perform an isolation check on the exposed metal parts of the product (antenna terminals, knobs, metal cabinet, screw heads, headphone jack, control shafts, etc.) to be sure the product is safe to operate without danger of electrical shock.

Do not use a line isolation transformer during this check.

- Plug the AC line cord directly into the AC outlet. Using a "Leakage Current Tester", measure the leakage current from each exposed metal parts of the cabinet, particularly any exposed metal part having a return path to the chassis, to a known good earth ground. Any leakage current must not exceed 0.5mA AC (r.m.s.).

- Alternate check method

Plug the AC line cord directly into the AC outlet. Use an AC voltmeter having, 1,000 ohms per volt or more sensitivity in the following manner. Connect a 1,500  $\Omega$  10W resistor paralleled by a 0.15  $\mu$ F AC-type capacitor between an exposed metal part and a known good earth ground. Measure the AC voltage across the resistor with the AC voltmeter.

Move the resistor connection to each exposed metal part, particularly any exposed metal part having a return path to the chassis, and measure the AC voltage across the resistor. Now, reverse the plug in the AC outlet and repeat each measurement. Any voltage measured must not exceed 0.75 V AC (r.m.s.). This corresponds to 0.5 mA AC (r.m.s.).

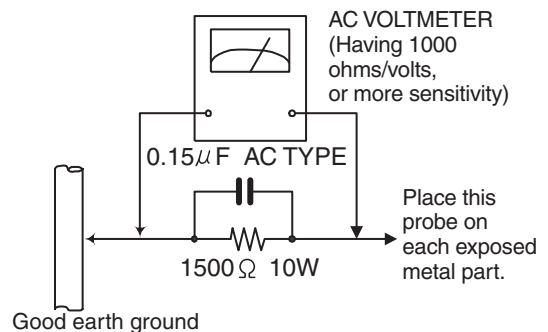

## Warning

1. This equipment has been designed and manufactured to meet international safety standards.
2. It is the legal responsibility of the repairer to ensure that these safety standards are maintained.
3. Repairs must be made in accordance with the relevant safety standards.
4. It is essential that safety critical components are replaced by approved parts.
5. If mains voltage selector is provided, check setting for local voltage.

## CAUTION

**Burrs formed during molding may be left over on some parts of the chassis. Therefore, pay attention to such burrs in the case of performing repair of this system.**

In regard with component parts appearing on the silk-screen printed side (parts side) of the PWB diagrams, the parts that are printed over with black such as the resistor (■), diode (▣) and ICP (●) or identified by the " $\triangle$ " mark nearby are critical for safety.

When replacing them, be sure to use the parts of the same type and rating as specified by the manufacturer. (Except the JC version)

# Important for laser products

1. **CLASS 1 LASER PRODUCT**
2. **DANGER** : Invisible laser radiation when open and interlock failed or defeated. Avoid direct exposure to beam.
3. **CAUTION** : There are no serviceable parts inside the Laser Unit. Do not disassemble the Laser Unit. Replace the complete Laser Unit if it malfunctions.
4. **CAUTION** : The compact disc player uses invisible laser radiation and is equipped with safety switches which prevent emission of radiation when the drawer is open and the safety interlocks have failed or are defeated. It is dangerous to defeat the safety switches.
5. **CAUTION** : If safety switches malfunction, the laser is able to function.
6. **CAUTION** : Use of controls, adjustments or performance of procedures other than those specified herein may result in hazardous radiation exposure.

**CAUTION** Please use enough caution not to see the beam directly or touch it in case of an adjustment or operation check.

**WARNING** : Osynlig laserstrålning är denna del är öppnad och spårren är urkopplad. Betrakta ej strålen.

**VARO** : Avattaessa ja suojalukitus ohitettaessa olet alltiina näkymättömälle lasersäteilylle. Älä katso säteeseen.

**ADVARSEL** : Usynlig laserstrålning ved åbning, når sikkerhedsafbrydere er ude af funktion. Undgå udsættelse for stråling.

**ADVARSEL** : Usynlig laserstrålning ved åbning, når sikkerhedsbryteren er avslott. unngå utsettelse for stråling.

## REPRODUCTION AND POSITION OF LABELS

### WARNING LABEL

DANGER : Invisible laser radiation when open and interlock or defeated.  
AVOID DIRECT EXPOSURE TO BEAM (e)

VARO : Avattaessa ja suojalukitus ohitettaessa olet alltiina näkymättömälle lasersäteilylle. Älä katso säteeseen. (d)

WARNING : Osynlig laserstrålning är denna del är öppnad och spårren är urkopplad. Betrakta ej strålen. (s)

ADVARSEL : Usynlig laserstrålning ved åbning, når sikkerhedsafbrydere er ude af funktion. Undgå udsættelse for stråling. (f)

**CLASS 1  
LASER PRODUCT**

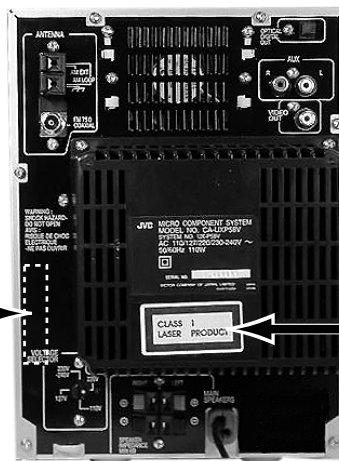

# Preventing static electricity

Electrostatic discharge (ESD), which occurs when static electricity stored in the body, fabric, etc. is discharged, can destroy the laser diode in the traverse unit (optical pickup). Take care to prevent this when performing repairs.

## 1.1. Grounding to prevent damage by static electricity

Static electricity in the work area can destroy the optical pickup (laser diode) in devices such as DVD players. Be careful to use proper grounding in the area where repairs are being performed.

### 1.1.1. Ground the workbench

1. Ground the workbench by laying conductive material (such as a conductive sheet) or an iron plate over it before placing the traverse unit (optical pickup) on it.

### 1.1.2. Ground yourself

1. Use an anti-static wrist strap to release any static electricity built up in your body.

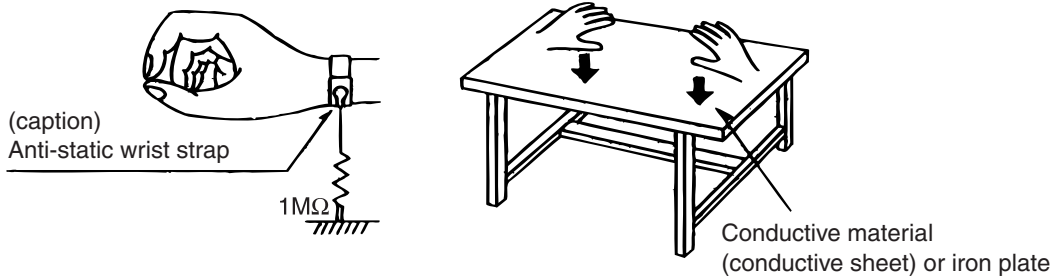

### 1.1.3. Handling the optical pickup

1. In order to maintain quality during transport and before installation, both sides of the laser diode on the replacement optical pickup are shorted. After replacement, return the shorted parts to their original condition. (Refer to the text.)
2. Do not use a tester to check the condition of the laser diode in the optical pickup. The tester's internal power source can easily destroy the laser diode.

## 1.2. Handling the traverse unit (optical pickup)

1. Do not subject the traverse unit (optical pickup) to strong shocks, as it is a sensitive, complex unit.
2. Cut off the shorted part of the flexible cable using nippers, etc. after replacing the optical pickup. For specific details, refer to the replacement procedure in the text. Remove the anti-static pin when replacing the traverse unit. Be careful not to take too long a time when attaching it to the connector.
3. Handle the flexible cable carefully as it may break when subjected to strong force.
4. It is not possible to adjust the semi-fixed resistor that adjusts the laser power. Do not turn it.

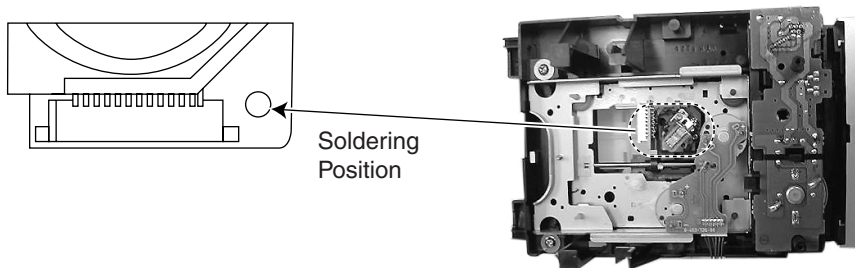

## Disassembly method

### <Main body>

#### ■ Removing the rear cover (See Fig. 1 & 2)

1. Remove the two screws **A** attaching the top of rear (heatsink) cover at the back of the body.
2. The (heatsink) cover now can be swing downwards to a horizontal position and detached.

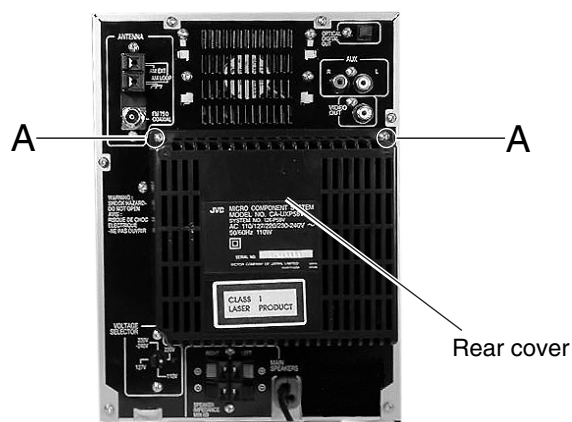

Fig. 1

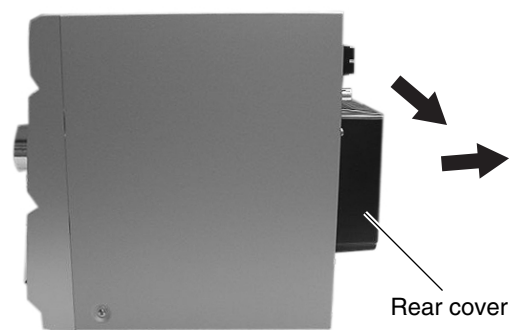

Fig. 2

#### ■ Removing the metal cover (See Fig. 3~5)

- Prior to performing the following procedure, remove the rear cover.
1. Remove the six screws **B** attaching the metal cover to the back panel.
  2. Remove the 2 screws **C** from each side of the metal cover.
  3. Holding the bottom edges on the rear of the metal cover, pull apart and swing the cover upwards. It can be detached by pulling upwards.

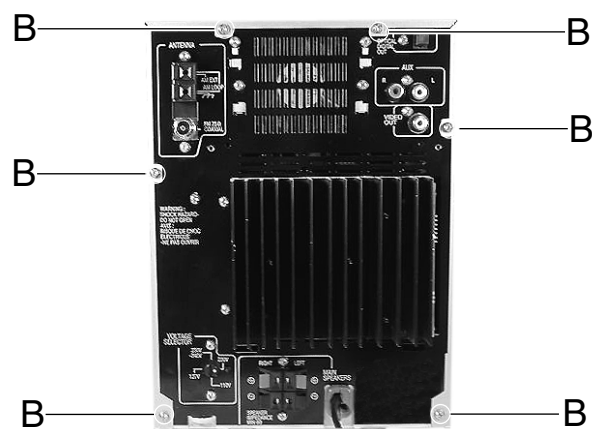

Fig. 3

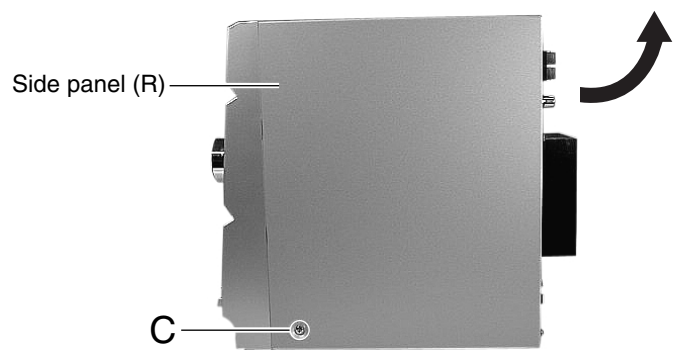

Fig. 4

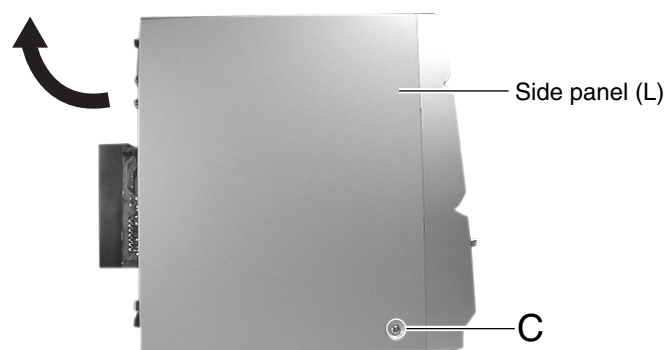

Fig. 5

■ **Removing the rear panel (See Fig. 6~8)**

- Prior to performing the following procedure, remove the rear cover and metal cover.

1. Remove the fourteen screws **D** attaching the rear panel.
2. Disconnect the card wire from connector CN908 on the main board respectively.
3. Unhook the CD mechanism assembly from the rear panel by pushing the two joints **a** upwards and pull the rear panel towards you.
4. At the bottom right side of the rear panel, pull outwards to release joints **b** and push backwards. The rear panel now can be removed.

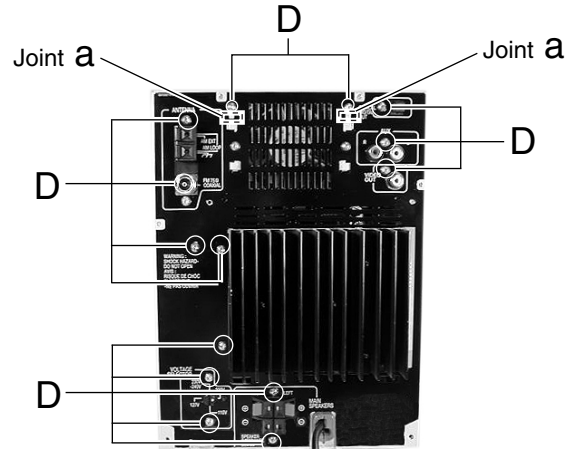

Fig. 6

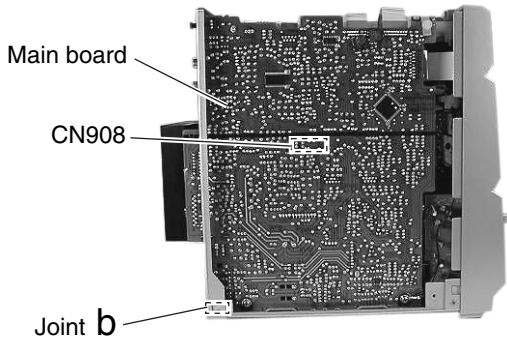

Fig. 7

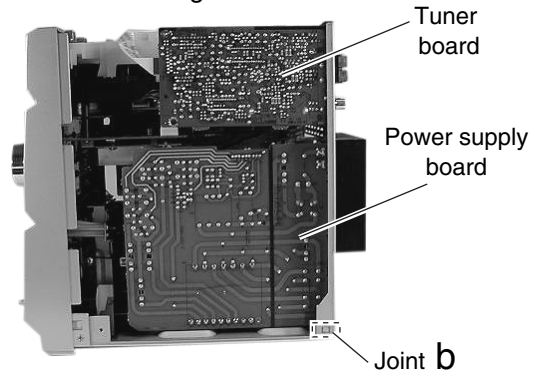

Fig. 8

■ **Removing the tuner board (See Fig. 9~10)**

- Prior to performing the following procedure, remove the rear cover, metal cover and the rear panel.

1. Disconnect the card wire from connector CN902 on the main board respectively.
2. Remove the screw **E** attaching the CD mechanism assembly on the left side of the body.

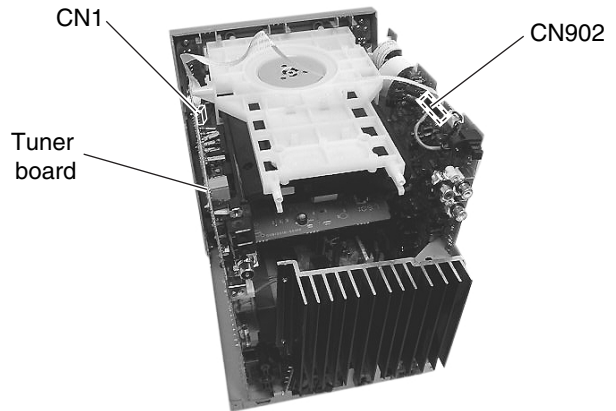

Fig. 9

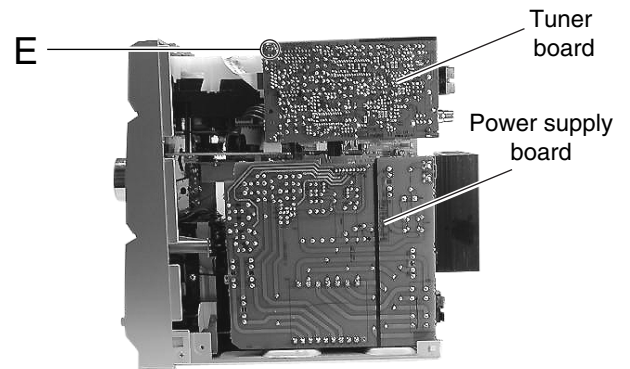

Fig. 10

## ■ Removing the CD mechanism assembly (See Fig. 11 & 12)

- Prior to performing the following procedure, remove the rear cover, metal cover, rear panel and tuner board.
1. Disconnect the card wires from connector CN903, CN904 and CN905 on the main board on the right side of the body.
  2. Lift the rear of the CD assembly slightly and pull out as indicated.

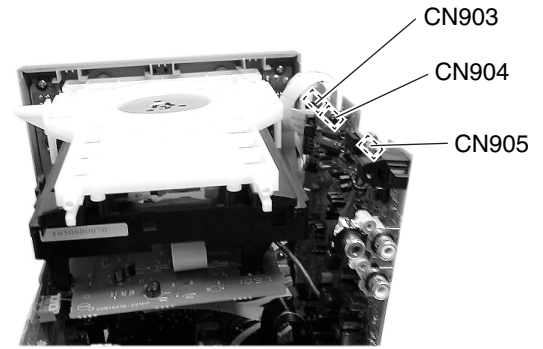

Fig. 11

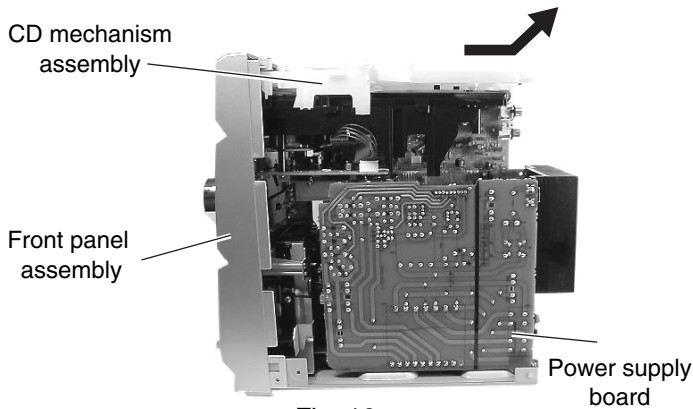

Fig. 12

## ■ Removing the main board / power amplifier board / heat sink (See Fig. 13 & 16)

- Prior to performing the following procedure, remove the rear cover, the side panels, tuner board CD mechanism assembly.
1. Disconnect the card wire from CN931 and CN933 on the operation switch board.
  2. Disconnect the card wire from CN906 on the head phone board.
  3. Disconnect the card wire from CN900 and CN901 on the cassette mechanism assembly.
  4. Disconnect the card wire from CN950 and CN951 on the power supply board.
  5. Remove two screws **F** from the side of the main board.
  6. Move the boards and heat sink assembly upwards and disengage the two joints **c** and joint **d** to release the power amplifier boards and the main board from the chassis.

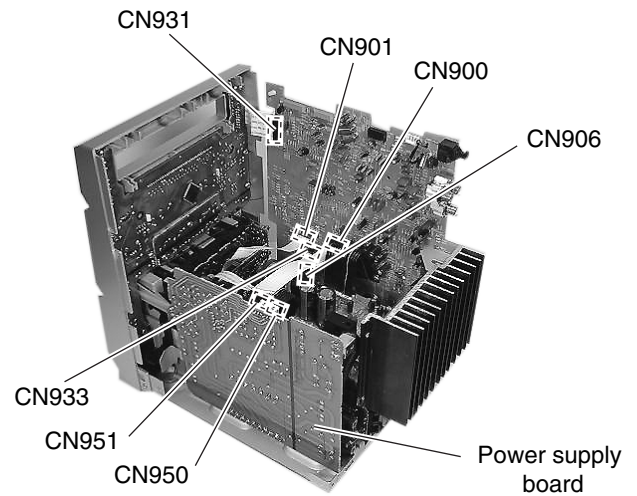

Fig. 13

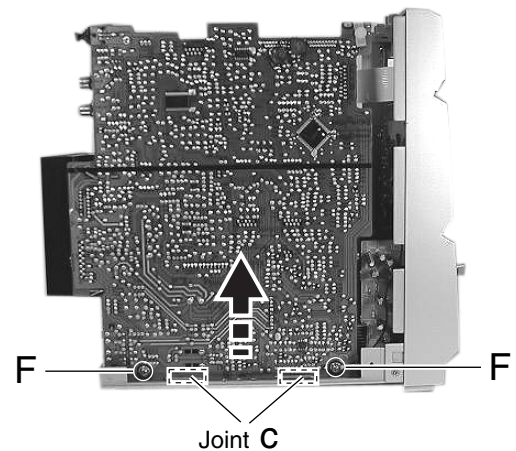

Fig. 14

**Attention:** The wire ring tongue terminals do not touch to any solder points at the main board. (See Fig. 16)

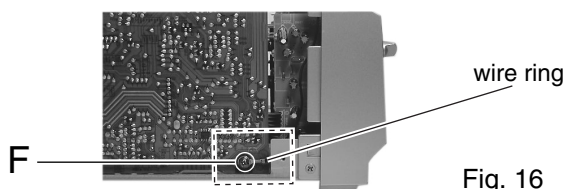

Fig. 16

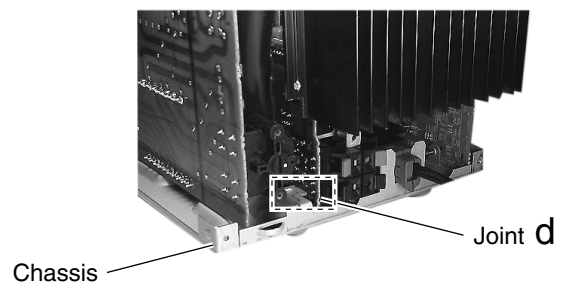

Fig. 15

**■ Removing the power amplifier board / power amplifier sub board / heat sink (See Fig. 17)**

- Prior to performing the following procedure, remove the rear cover, metal cover, tuner board, CD mechanism assembly and main board.
1. Disconnect the card wires from connector CN944, CN945 and CN946 on the power amplifier sub board.
  2. Remove the two screws **G** attaching the power amplifier board and the heat sink.

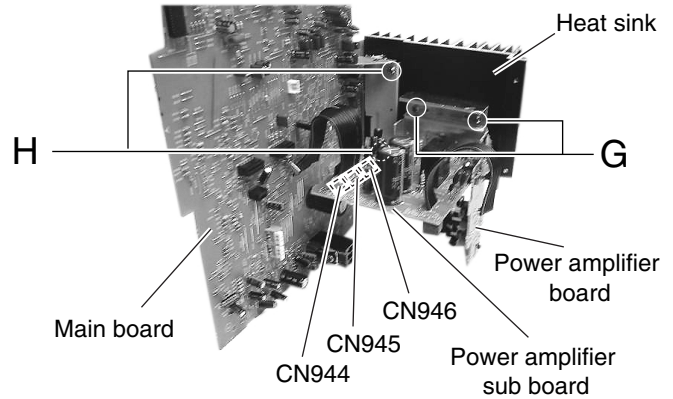

Fig. 17

**■ Removing the heat sink (See Fig. 17)**

- Prior to performing the following procedure, remove the power amplifier board.
1. Remove the two screws **H** attaching the main board and the heat sink.

**■ Removing the power cable (See Fig. 18)**

- Prior to performing the following procedure, remove the rear cover, metal cover, tuner board, CD mechanism assembly and main board.
1. Disconnect the card wires from J1000 on the power supply board by pressing down on the clip and pull out the cable point.
  2. Pull up the cord stopper as the direction of the arrow.

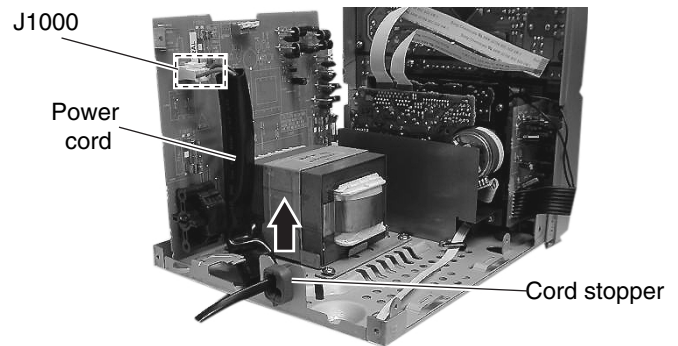

Fig. 18

**■ Removing the power supply board and the power transformer (See Fig. 19)**

- Prior to performing the following procedure, remove the rear cover, metal cover, tuner board, CD mechanism assembly, main board and power cable.
1. The power transformer assembly is soldered to the power supply board.
  2. Remove the four screws **I** attaching the power transformer assembly from the chassis.
  3. Once unscrewed, remove it by lifting the power transformer assembly.

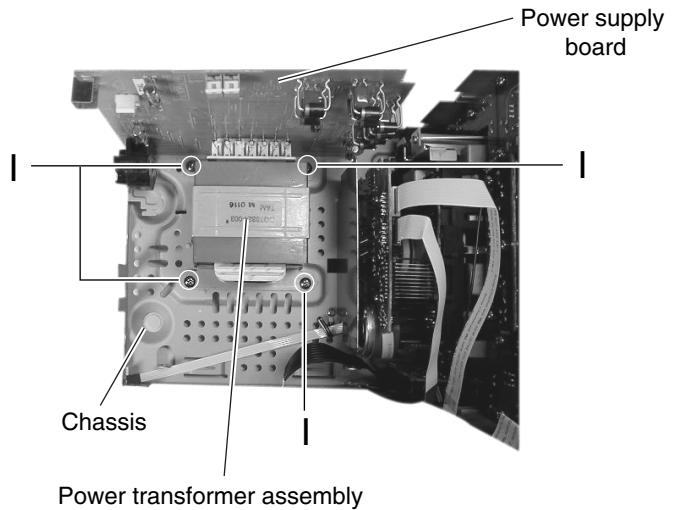

Fig. 19



## <Front panel assembly>

- Prior to performing the following procedure, remove the rear cover, metal cover, tuner board, CD mechanism assembly, main board, power supply board with the power transformer

### ■ Removing the front panel assembly (See Fig. 20 & 21)

1. Remove the two screws **J** on each lower side of the body.
2. Release the joints **e** on each side of the body using a screwdriver.
3. Pull out the front panel assembly toward the front.

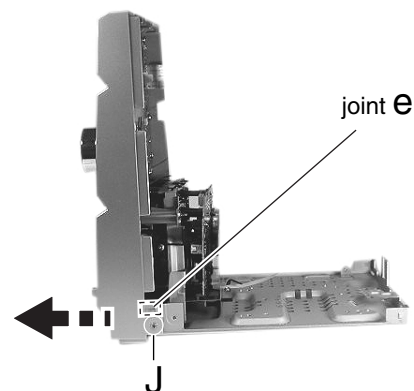

Fig. 20

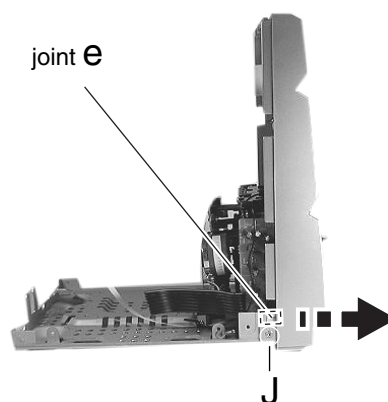

Fig. 21

### ■ Removing the cassette mechanism assembly (See Fig. 22 & 23)

1. Press the EJECT button on the front panel to open the cassette door.
2. Remove the four screws **K** attaching the front panel.
3. The mecha bracket is removed together.

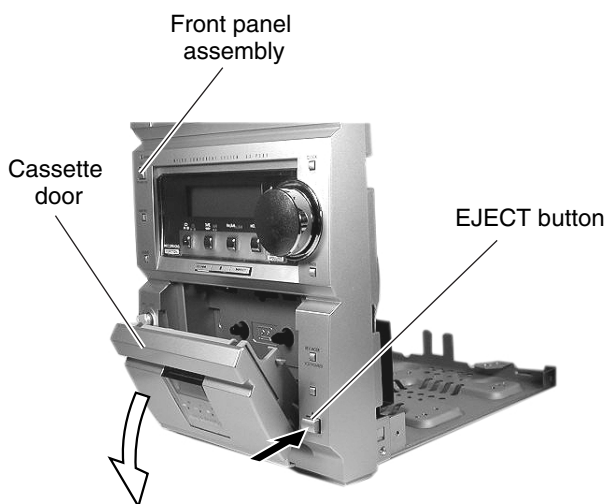

Fig. 22

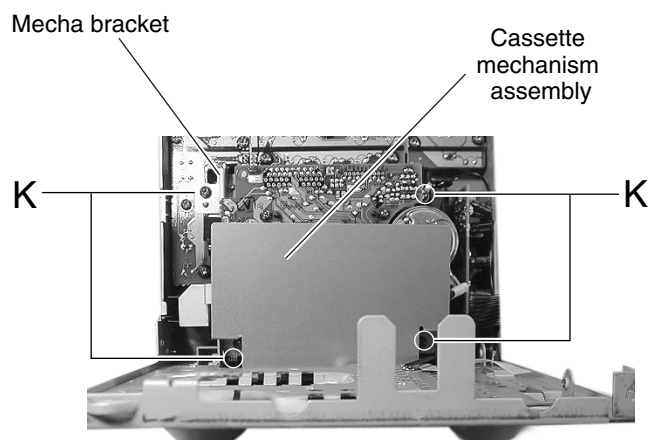

Fig. 23

## ■ Removing the operation switch board (See Fig. 24 & 25)

- Prior to performing the following procedure, remove the cassette mechanism assembly.
1. Pull out the VOLUME knob and subwoofer level knob on the front panel.
  2. Remove the thirteen screws **L** attaching the display board and the switch board on the back of the front panel. Remove the display board with the switch board.
  3. Remove the screw **M** attaching the switch board to the LCD holder.

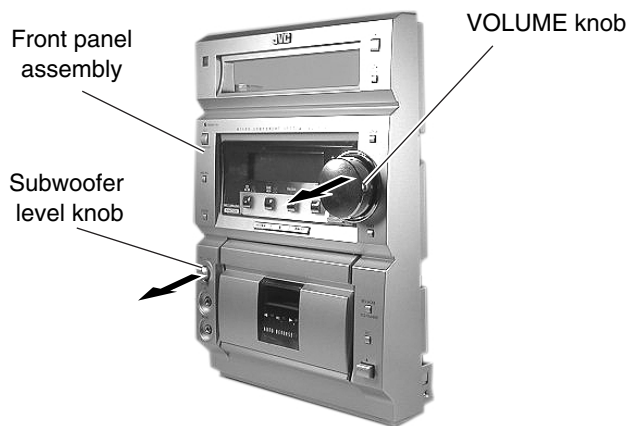

Fig. 24

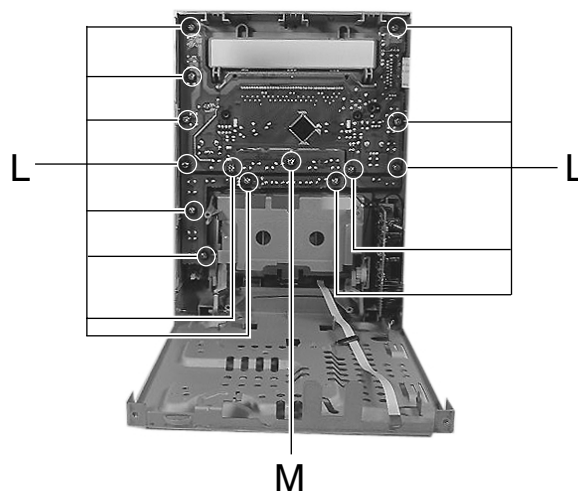

Fig. 25

## ■ Removing the head phone and microphone board (See Fig. 26)

- Prior to performing the following procedure, remove the cassette mechanism assembly and operation switch board.
1. Remove the two screws **N** attaching the head phone and microphone board.
  2. The MIC level knob will detach from the front as you pulled out.

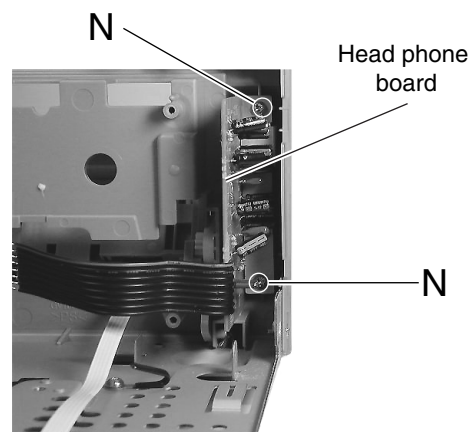

Fig. 26

■ **Removing the fan** (See Fig. 27 & 28)

- Prior to performing the following procedure, remove the rear cover, metal cover and the CD mechanism assembly.
1. Disconnect the wire from connector CN908 on the main board.
  2. Remove the two screws **O** attaching to the rear panel.
  3. Pull up the fan by releasing the four joints **f** at the rear panel.

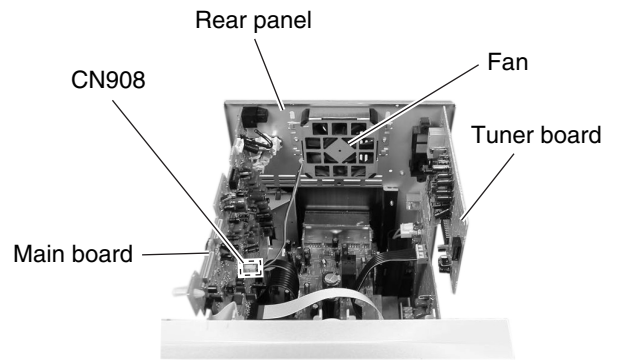

Fig. 27

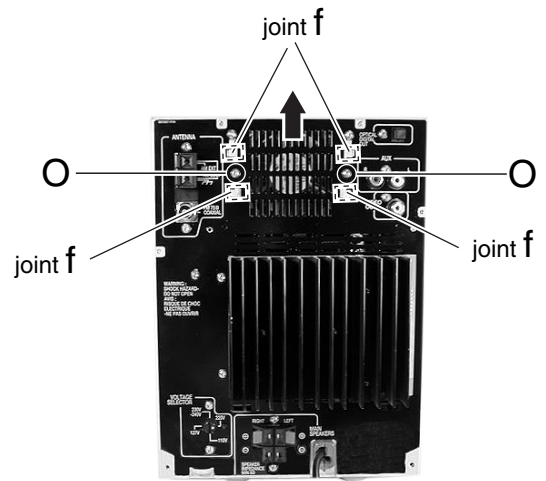

Fig. 28

### <CD mechanism assembly>

- Prior to performing the following procedure, remove the rear cover, metal cover, tuner board and CD mechanism assembly.

### ■ Removing the video board

(See Fig. 29 & 30)

1. Disconnect the card wire from connector CN101 on the video board.
2. Remove four screws **P** on the video board cover.
3. Remove the video board by lifting the board from the holder **g**.

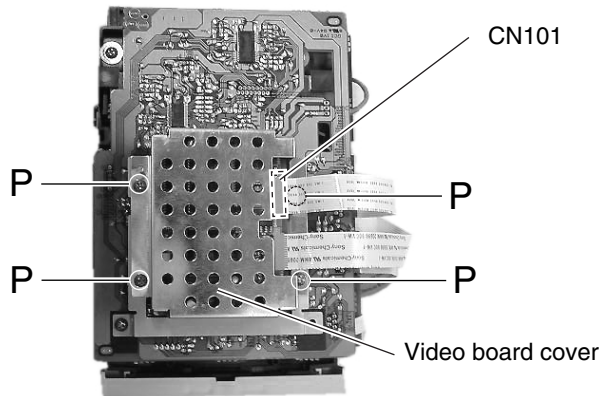

Fig. 29

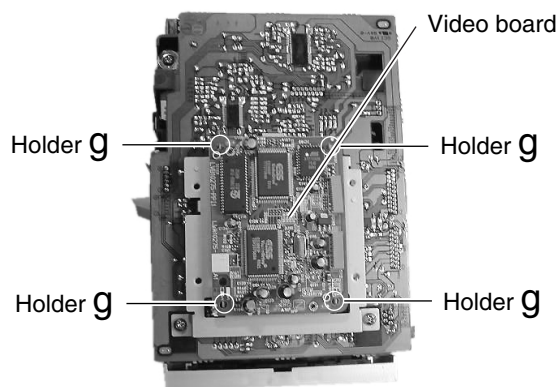

Fig. 30

### ■ Removing the CD servo control board

(See Fig. 31 & 32)

- Prior to performing the following procedure, remove the video board.
1. Remove two screws **Q** on the shield case, pull down lift up the shield case in the direction of the arrow by releasing the joint **h**.
  2. Disconnect the card wires from the connector CN601, CN606 and CN801 on the sub board.
  3. Pull down the CD servo control board in the direction of the arrow by releasing the joint **i**.

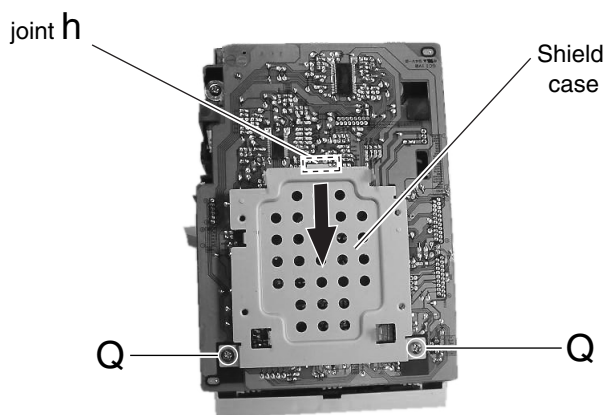

Fig. 31

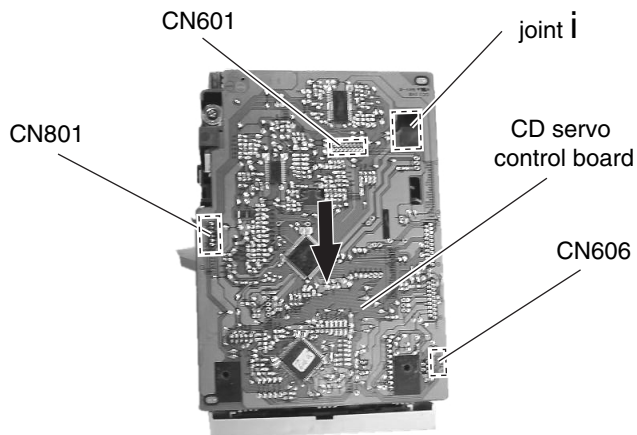

Fig. 32

## <Cassette mechanism section>

### ■ Removing the playback/recording and eraser heads (See Fig. 1~3)

1. While shifting the trigger arms seen on the right side of the head mount in the arrow direction, turn the flywheel R in counterclockwise direction until the head mount clicks. (See Fig. 1)
2. When the flywheel R is rotated in counterclockwise direction, the playback head will be turned in counterclockwise direction from the position in Fig. 2 to that in Fig. 3.
3. At this position, disconnect the flexible board (outgoing from the playback/recording & eraser head) from the connector CN31 on the head amplifier and mechanism control board.
4. After dismantling the FPC holder, remove the flexible board.
5. Remove the flexible board from the chassis base.
6. Remove the spring "a" from behind the playback/recording & eraser head.
7. Loosen the reversing azimuth screw retaining the playback/recording & eraser head.
8. Take out the playback/recording & eraser head from the front of the head mount.
9. The playback/recording & eraser heads should also be removed similarly according to Steps 1~8 above.

### ■ Reassembling the playback/recording and eraser heads (See Fig. 2 & 3)

1. Reassemble the playback head from the front of the head mount to the position as shown in Fig. 3.
2. Fix the reversing azimuth screw.
3. Set the spring "a" from behind the playback/recording & eraser head.
4. Attach the flexible board to the chassis base, and fix it with the FPC holder as shown in Fig. 3.
5. The playback/recording & eraser heads should also be reassembled similarly according to Steps 1~4 above.

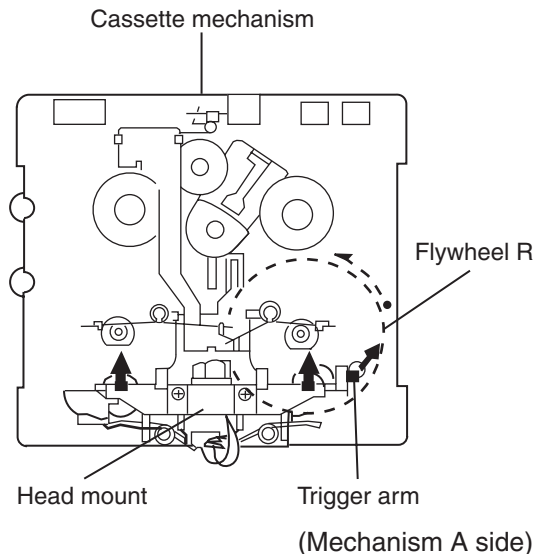

Fig. 1

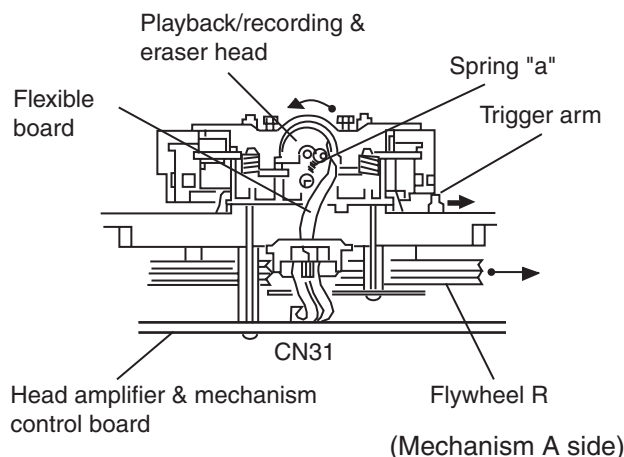
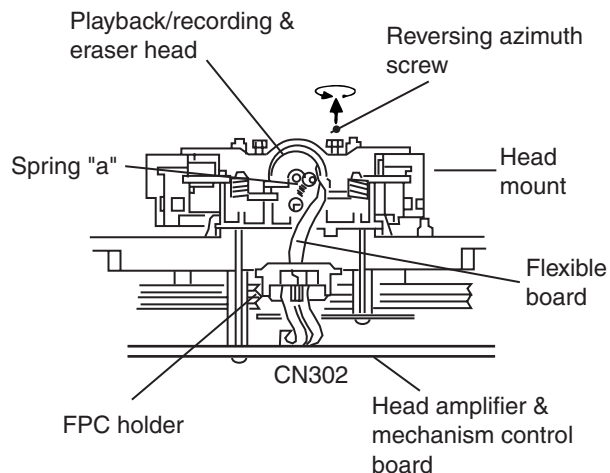

Fig. 2



(Mechanism B side)

Fig. 3

**■ Removing the head amplifier and mechanism control board (See Fig. 4)**

1. Remove the cassette mechanism assembly.
2. After turning over the cassette mechanism assembly, remove the three screws **A** retaining the head amplifier and mechanism control board.
3. Disconnect the connectors CN32 on the board and the connectors CN31 on both the right and left side reel pulse boards.
4. When necessary, remove the 4 pin parallel wire soldered to the main motor.

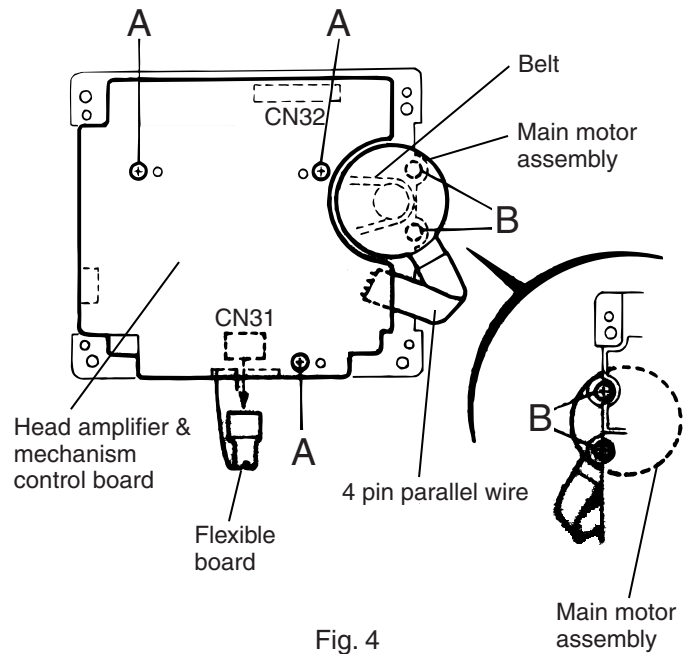

Fig. 4

**■ Removing the main motor assembly (See Fig. 4~7)**

1. Remove the two screws **B** retaining capstan motor assembly. (See Fig. 4)
2. While raising the capstan motor, remove the capstan belts from the motor pulley. (See Fig. 5)

**Caution:** Be sure to handle the capstan belts carefully so that these belts will not be stained by grease and other foreign matter. Moreover, these belts should be hang while referring to the capstan belt hanging method in Fig. 6 and 7.

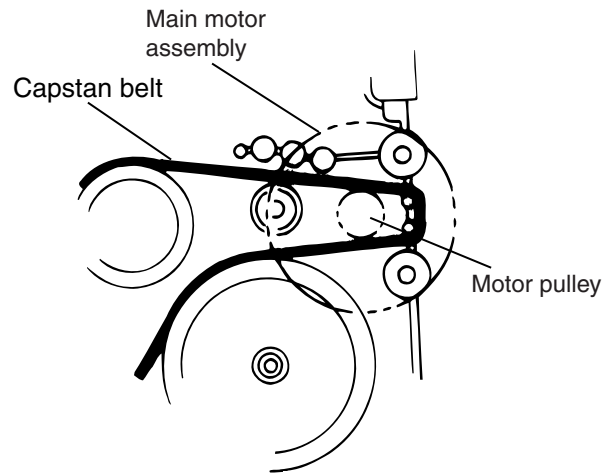

Fig. 5

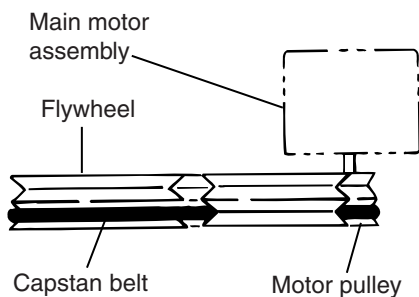

Fig. 6

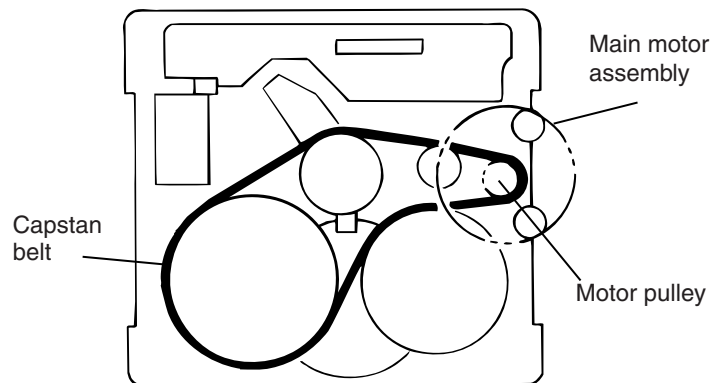

Fig. 7

## ■ Removing the flywheel (See Fig. 8 & 9)

1. Remove the head amp. and mechanism control board.
2. Remove the capstan motor assembly.
3. After turning over the cassette mechanism, remove the slit washers "a" and "b" fixing the capstan shafts R and L, and pull out the flywheels R and L respectively from behind the cassette mechanism.

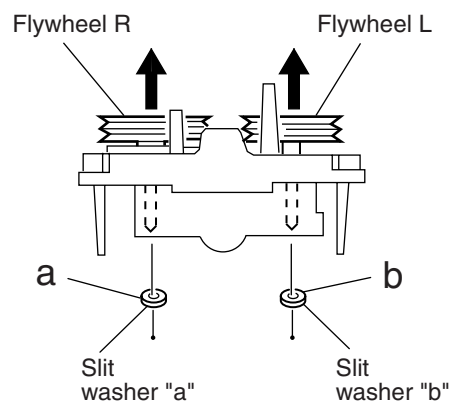

Fig. 8

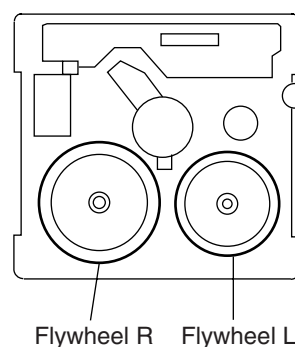

Fig. 9

## ■ Removing the reel pulse board and solenoid (See Fig. 10)

1. Remove the five pawls (c, d, e, f, g) retaining the reel pulse board.
2. From the surface of the reel pulse board parts, remove the two pawls h and i retaining the solenoid.

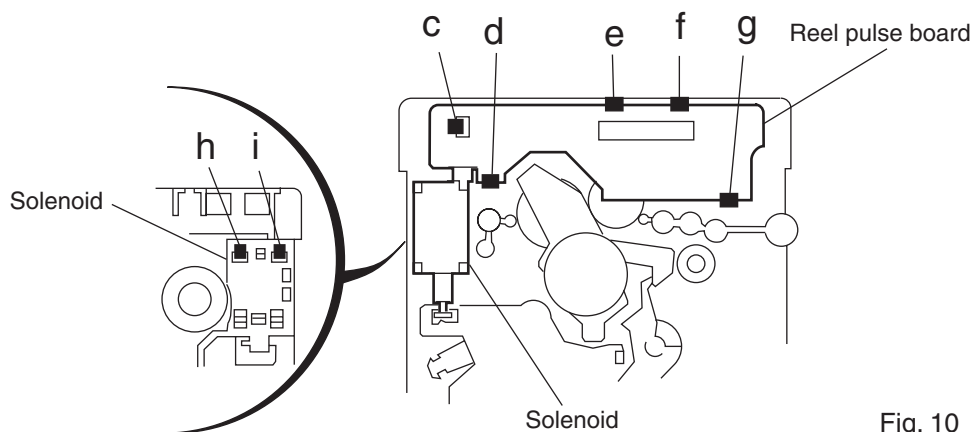

Fig. 10

# Adjustment method

## ■ Measurement instruments required for adjustment

1. Low frequency oscillator  
This oscillator should have a capacity to output 0dBs to 600  $\Omega$  at an oscillation frequency of 50Hz-20kHz.
2. Attenuator impedance : 600  $\Omega$
3. Electronic voltmeter
4. Distortion meter
5. Frequency counter
6. Wow & flutter meter
7. Test tape  
VT703L : Head azimuth  
VT712 : Tape speed and running unevenness (3kHz)  
VT724 : Reference level (1kHz)
8. Blank tape  
TYPE I : AC-225  
TYPE II : AC-514
9. Torque gauge : For play and back tension  
FWD (TW2111A), REV (TW2121a) and  
FF/REW (TW2231A)
10. Test disc : CTS-1000

## ■ Measurement conditions

Power supply voltage

: AC110/127V/230V (50/60Hz)

Reference output : Speaker : 0.775V/4  $\Omega$

: Headphone : 0.077V/32  $\Omega$

Reference frequency and

input level ----- 1kHz, AUX : -8dBs

MIX MIC : -54dBs

Input for confirming recording and playback

characteristics ----- AUX : -28dBs

Measurement output terminal ----- at Speaker J300

※ Load resistance ----- 4  $\Omega$

## ● Radio input signal

AM frequency ----- 400Hz

AM modulation ----- 30%

FM frequency ----- 400Hz

FM frequency deviation ----- 22.5kHz

## ● Tuner section

FM Band cover : 87.5 ~ 108MHz

MW Band cover : 531 ~ 1,602kHz, 530 ~ 1,710kHz

SW Band cover : SW1 2.3 ~ 6.995MHz

: SW2 7 ~ 21.85MHz

Voltage applied to tuner ----- +B : DC5.7V

VT : DC 12V

Reference measurement

output ----- 26.1mV (0.28V)/ 3  $\Omega$

Input positions ----- AM : Standard loop antenna

FM : TP1 (hot) and TP2 (GND)

## ● Standard measurement position of volume

Function switch ----- to Tape

Beat cut switch ----- to cut

Super Bass/ Active hyper Bass ----- to OFF

Bass Treble ----- to Center

Adjustment of main volume to reference output

VOL : 28

## ● Precautions for measurement

1. Apply 30pF and 33k  $\Omega$  to the IF sweeper output side and 0.082  $\mu$ F and 100k  $\Omega$  in series to the sweeper input side.
2. The IF sweeper output level should be made as low as possible within the adjustable range.
3. Since the IF sweeper is a fixed device, there is no need to adjust this sweeper.
4. Since a ceramic oscillator is used, there is no need to perform any MIX adjustment.
5. Since a fixed coil is used, there is no need to adjust the FM tracking.
6. The input and output earth systems are separated. In case of simultaneously measuring the voltage in both of the input and output systems with an electronic voltmeter for two channels, therefore, the earth should be connected particularly carefully.
7. In the case of BTL connection amp., the minus terminal of speaker is not for earthing. Therefore, be sure not to connect any other earth terminal to this terminal. This system is of an BTL system.
8. For connecting a dummy resistor when measuring the output, use the wire with a greater code size.
9. Whenever any mixed tape is used, use the band pass filter (DV-12).



■ Arrangement of adjusting positions

Cassette mechanism section

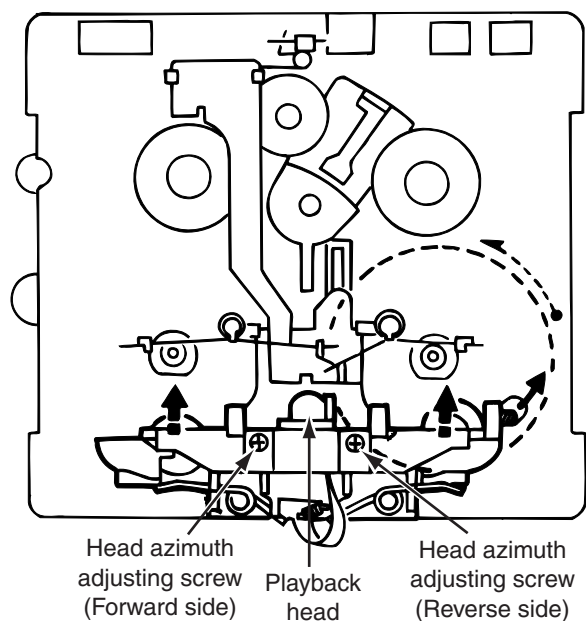

Cassette mechanism section (Rear side)

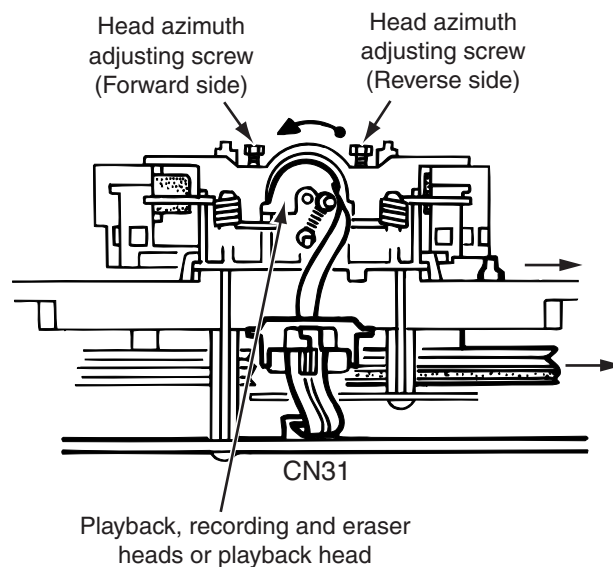

Front panel assembly section

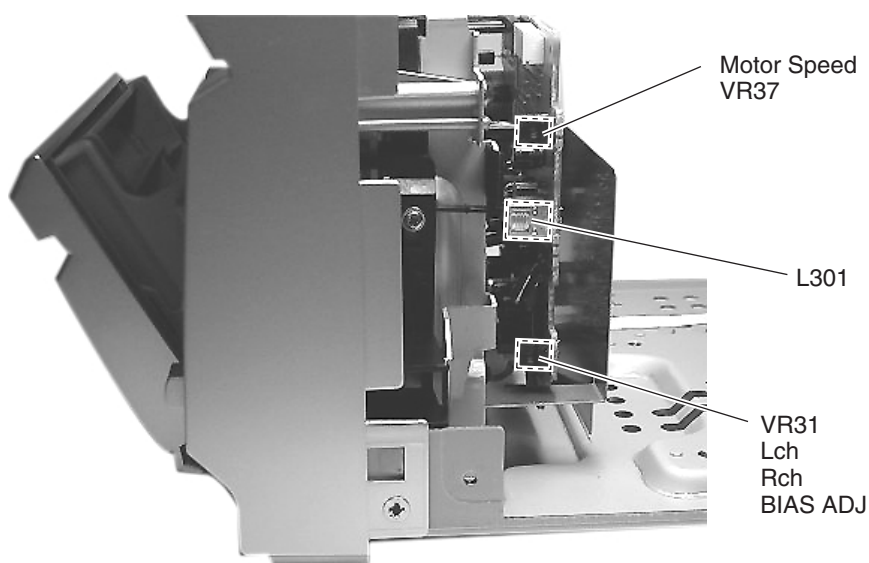

## ■ Tape Recorder Section

Items	Measurement conditions	Measurement method	Standard Values	Adjusting positions
Confirmation of head angle	Test tape : VT703L (8kHz) Measurement output terminal : Speaker terminal Speaker R (Load resistance : 4 Ω) : Headphone terminal	1. Playback the test tape VT703L (8kHz). 2. With the recording & playback mechanism, adjust the head azimuth screw so that the forward and reverse output levels become maximum. After adjustment, lock the head azimuth at least by half turn. 3. In either case, this adjustment should be performed in both the forward and reverse directions with the head azimuth screw.	Maximum output	Adjust the head azimuth screw only when the head has been changed.
Confirmation of tape speed	Test tape : VT712 (3kHz) Measurement output terminal : Headphone terminal	Adjust VR37 so that the frequency counter reading becomes 2,940 ~ 3,090Hz ± when playing back the test tape VT712 (3kHz) with playback and recording mechanism after ending forward winding of the tape.	Tape speed of deck : 2,940 ~ 3,090Hz	VR37

## ■ Reference Values for Confirmation Items

Items	Measurement conditions	Measurement method	Standard Values	Adjusting positions
Difference between the forward and reverse speed	Test tape : VT712 (3kHz) Measurement output terminal : Speaker terminal Speaker R (Load resistance:4 Ω) Measurement output terminal : Headphone	When the test tape VT712 (3kHz) has been played back with the recording and playback mechanism at the beginning of forward winding, the frequency counter reading of the difference between both of the mechanism should be 6.0Hz or less.	60Hz or less	Head azimuth screw
Wow & flutter	Test tape : VT712 (3kHz) Measurement output terminal : Headphone terminal	When the test tape VT712 (3kHz) has been played back with the recording and playback mechanism at the beginning of forward winding, the frequency counter reading of wow & flutter should be 0.25% or less (WRMS).	0.25% or less (WRMS)	

## ■ Electrical Performance

Items	Measurement conditions	Measurement method	Standard Values	Adjusting positions
Adjustment of recording bias current (Reference Value)	<ul style="list-style-type: none"> <li>▪ Mode : Forward or reverse mode</li> <li>▪ Recording mode</li> <li>▪ Test tape : AC-514 to TYPE II and AC-225 to TYPE I</li> </ul> Measurement output terminal : Both recording and headphone terminals	<ol style="list-style-type: none"> <li>1. With the recording and playback mechanism, load the test tapes (AC-514 to TYPE II and AC-225 to TYPE I), and set the mechanism to the recording and pausing conditions in advance.</li> <li>2. After connecting 100 <math>\Omega</math> in series to the recorder head, measure the bias current with a valve voltmeter at both of the terminals.</li> <li>3. After resetting the [PAUSE] mode, start recording. At this time, adjust VR31 for LcH and VR32 for RcH so that the recording bias current values become 4.0 <math>\mu</math> A (TYPE I) and 4.20 <math>\mu</math> A (TYPE II).</li> </ol>	AC-225 : 4.20 $\mu$ A AC-514 : 4.0 $\mu$ A	L cH : VR31 R cH : VR32
Adjustment of recording and playback frequency characteristics	Reference frequency : 1kHz and 10kHz (REF.: -20dB) Test tape II : AC-514 to TYPE II Measurement input terminal : OSC IN	<ol style="list-style-type: none"> <li>1. With the recording and playback mechanism, load the test tapes (AC-514 to TYPE II), and set the mechanism to the recording and pausing condition in advance.</li> <li>2. While repetitively inputting the reference frequency signal of 1kHz and 10kHz from OSC IN, record and playback the tape.</li> <li>3. While recording and playing back the test tape in TYPE II, adjust VR31 for LcH and VR32 for RcH so that the output deviation between 1kHz and 10kHz becomes -1dB <math>\pm</math> 2dB.</li> </ol>	Output deviation between 1kHz and 10kHz : -1dB $\pm$ 2dB	LcH : VR31 RcH : VR32

## ■ Reference Values for Electrical Function Confirmation Items

Items	Measurement conditions	Measurement method	Standard Values	Adjusting positions
Recording bias frequency	Forward or reverse <ul style="list-style-type: none"> <li>▪ Test tape : TYPE II (AC-514)</li> <li>▪ Measurement terminal BIAS TP on board</li> </ul>	<ol style="list-style-type: none"> <li>1. While changing over to and from BIAS 1 and 2, confirm that the frequency is changed.</li> <li>2. With the recording and playback mechanism, load the test tape. (AC-514 to TYPE II), and set the mechanism to the recording and pausing condition in advance.</li> <li>3. Confirm that the BIAS TP frequency on the board is 100kHz <math>\pm</math> 6kHz.</li> </ol>	100kHz $\pm$ 6 kHz	
Eraser current (Reference value)	Forward or reverse <ul style="list-style-type: none"> <li>▪ Recording mode</li> <li>▪ Test tape : AC-514 to TYPE II and AC-225 to TYPE I</li> </ul> Measurement terminal : Both of the eraser head terminals	<ol style="list-style-type: none"> <li>1. While recording and playback mechanism, load the test tapes (AC-514 to TYPE II and AC-225 to TYPE I), and set the mechanism to the recording and pausing conditions in advance.</li> <li>2. After setting to the recording conditions, connect 1W in series to the eraser head on the recording and playback mechanism side, and measure the eraser current from both of the eraser terminals.</li> </ol>	TYPE II : 120 mA TYPE I : 75 mA	

# Flow of functional operation until TOC read

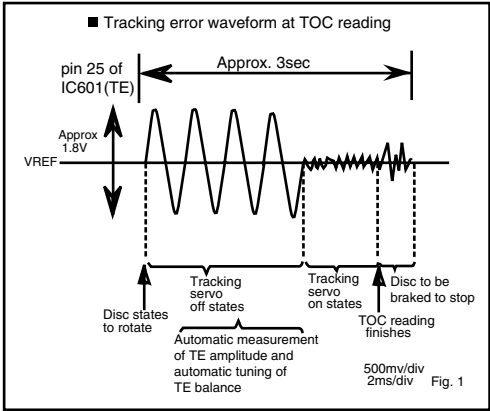
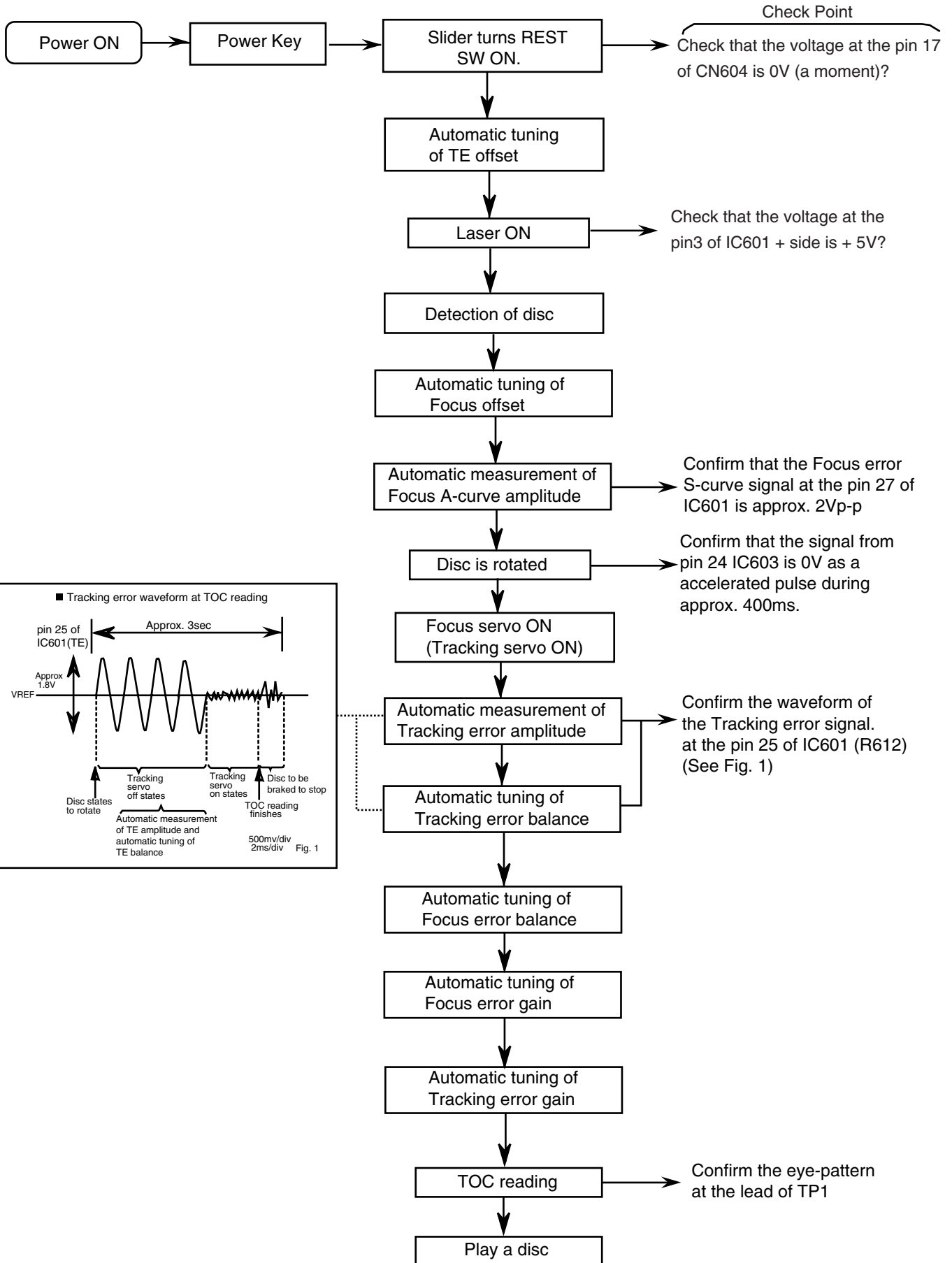

## Maintenance of laser pickup

- (1) Cleaning the pickup lens  
Before you replace the pickup, please try to clean the lens with an alcohol soaked cotton swab.
- (2) Life of the laser diode  
When the life of the laser diode has expired, the following symptoms will appear.
  1. The level of RF output (EFM output: amplitude of eye pattern) will below.

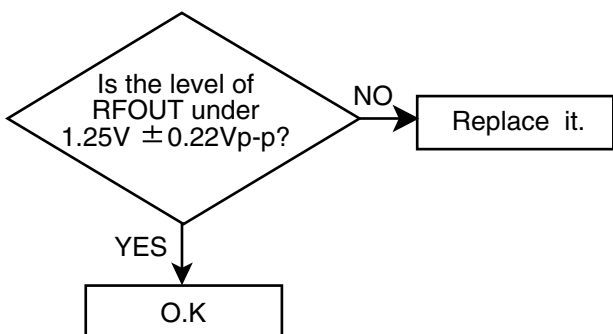

- (3) Semi-fixed resistor on the APC board  
The semi-fixed resistor on the APC board which is attached to the pickup is used to adjust the laser power. Since this adjustment should be performed to match the characteristics of the whole optical block, do not touch the semi-fixed resistor.  
If the laser power is lower than the specified value, the laser diode is almost worn out, and the laser pickup should be replaced.  
If the semi-fixed resistor is adjusted while the pickup is functioning normally, the laser pickup may be damaged due to excessive current.

## Replacement of laser pickup

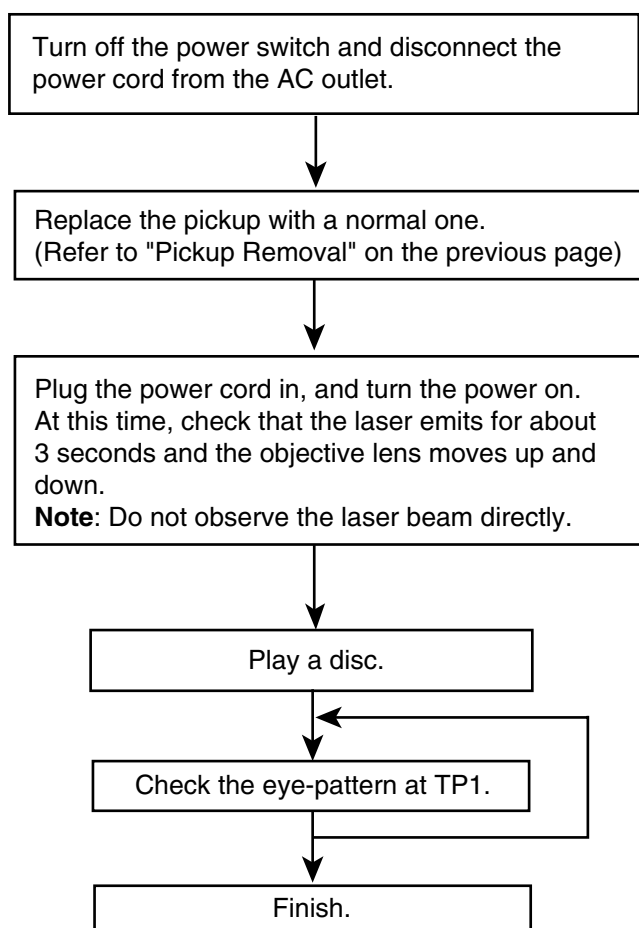

# Description of major ICs

## ■ MN662748RPMFA (IC651) : Digital servo & Digital signal processor

### 1. Pin layout

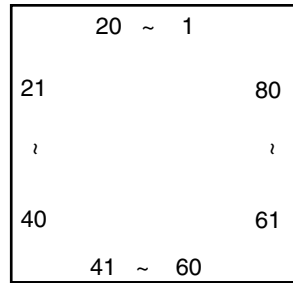

### 2. Block diagram

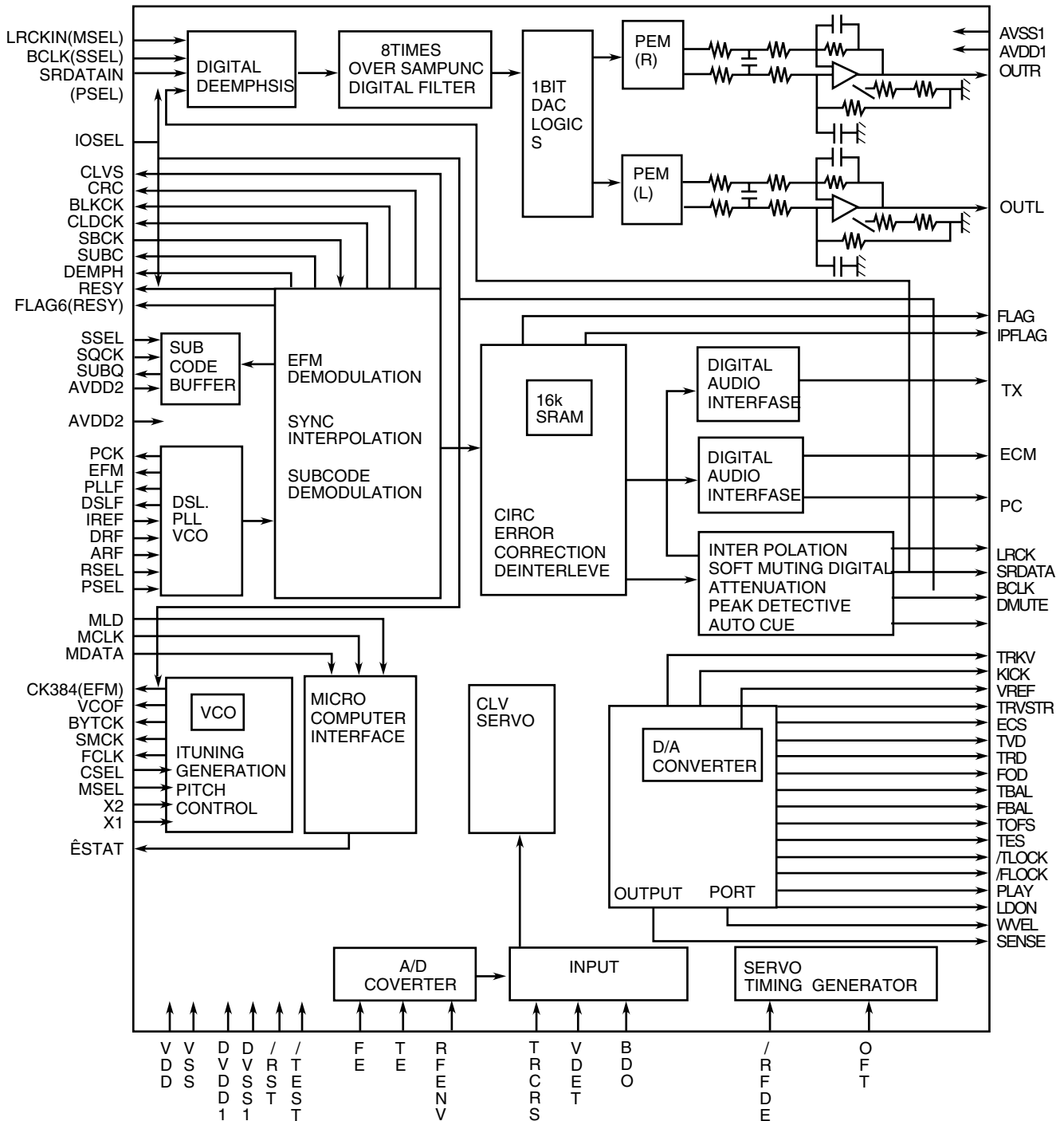

## 3. Pin function

Pin No.	Symbol	I/O	Function	Pin No.	Symbol	I/O	Function
1	BCLK	O	Not used	41	TES	O	Tracking error shunt signal output (H:shunt)
2	LRCK	O	Not used	42	PLAY	—	Not used
3	SRDATA	O	Not used	43	WVEL	—	Not used
4	DVDD1	—	Power supply (Digital)	44	ARF	I	RF signal input
5	DVSS1	—	Connected to GND	45	IREF	I	Reference current input pin
6	TX	O	Digital audio interface output	46	DRF	I	Bias pin for DSL
7	MCLK	I	CPU command clock signal input (Data is latched at signal's rising point)	47	DSLIF	I/O	Loop filter pin for DSL
8	MDATA	I	CPU command data input	48	PLLIF	I/O	Loop filter pin for PLL
9	MLD	I	CPU command load signal input	49	VCOF	—	Not used
10	SENSE	O	Sense signal output	50	AVDD2	—	Power supply (Analog)
11	FLOCK	O	Focus lock signal output Active : Low	51	AVSS2	—	Connected to GND (Analog)
12	TLOCK	O	Tracking lock signal output Active : Low	52	EFM	—	Not used
13	BLKCK	O	sub-code/block/clock signal output	53	PCK	—	Not used
14	SQCK	I	Outside clock for sub-code Q resister input	54	PDO	—	Not used
15	SUBQ	O	Sub-code Q -code output	55	SUBC	—	Not used
16	DMUTE	—	Connected to GND	56	SBCK	—	Not used
17	STATUS	O	Status signal (CRC, CUE, CLVS, TTSTOP, ECLV, SQOK)	57	VSS	—	Connected to GND (for X'tal oscillation circuit)
18	RST	I	Reset signal input (L : Reset)	58	X1	I	Input of 16.9344MHz X'tal oscillation circuit
19	SMCK	—	Not used	59	X2	O	Output of X'tal oscillation circuit
20	PMCK	—	Not used	60	VDD	—	Power supply (for X'tal oscillation circuit)
21	TRV	O	Traverse enforced output	61	BYTCK	—	Not used
22	TVD	O	Traverse drive output	62	CLDCK	—	Not used
23	PC	—	Not used	63	FLAG	—	Not used
24	ECM	O	Spindle motor drive signal (Enforced mode output) 3-State	64	IPPLAG	—	Not used
25	ECS	O	Spindle motor drive signal (Servo error signal output)	65	FLAG	—	Not used
26	KICK	O	Kick pulse output	66	CLVS	—	Not used
27	TRD	O	Tracking drive output	67	CRC	—	Not used
28	FOD	O	Focus drive output	68	DEMPH	—	Not used
29	VREF	I	Reference voltage input pin for D/A output block (TVD, FOD, FBA, TBAL)	69	RESY	—	Not used
30	FBAL	O	Focus Balance adjust signal output	70	IOSEL	—	pull up
31	TBAL	O	Tracking Balance adjust signal output	71	TEST	—	pull up
32	FE	I	Focus error signal input (Analog input)	72	AVDD1	—	Power supply (Digital)
33	TE	I	Tracking error signal input (Analog input)	73	OUT L	O	Lch audio output
34	RF ENV	I	RF envelope signal input (Analog input)	74	AVSS1	—	Connected to GND
35	VDET	I	Vibration detect signal input (H : detect)	75	OUT R	O	Rch audio output
36	OFT	I	Off track signal input (H : off track)	76	RSEL	—	pull up
37	TRCRS	I	Track cross signal input	77	CSEL	—	Connected to GND
38	RFDET	I	RF detect signal input (L : detect)	78	PSEL	—	Connected to GND
39	BDO	I	BDO input pin (L : detect)	79	MSEL	—	Connected to GND
40	LDON	O	Laser ON signal output (H : on)	80	SSEL	—	Pull up

■ LC75345M-X (IC901) : E.volume

1. Pin layout

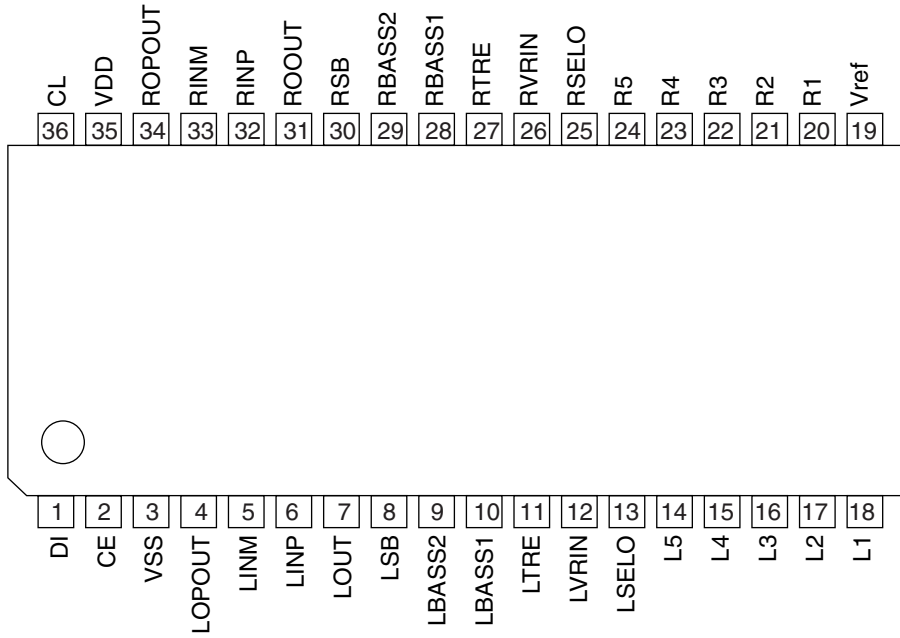

2. Block diagram

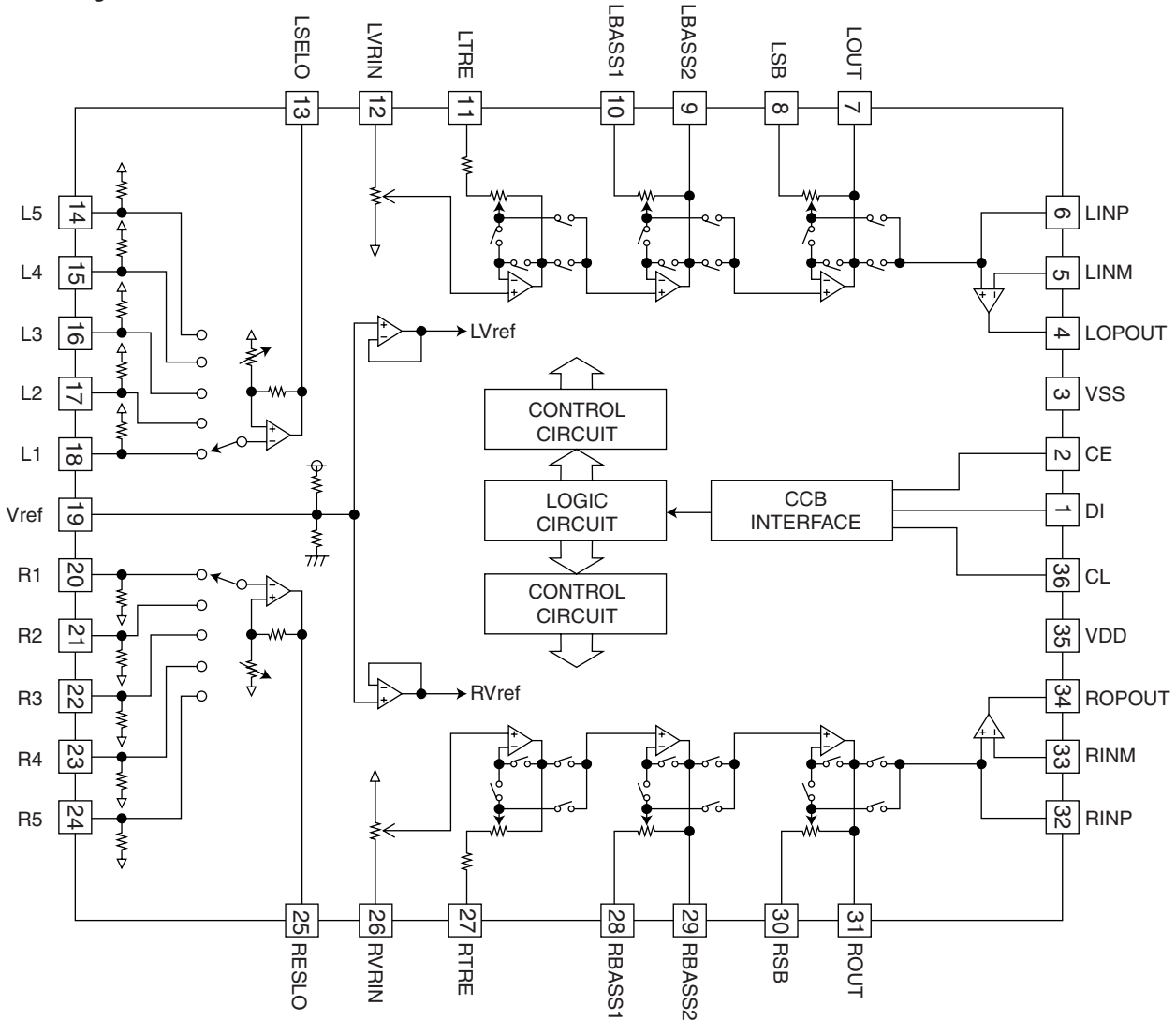



## 3. Pin function

Pin No.	Symbol	Function
1	DI	Serial data and clock input pin for control.
2	CE	Chip enable pin.
3	VSS	Ground pin.
4	LOPOUT	Output pin of general-purpose operation amplifier.
5	LINM	Non-inverted input pin of general-purpose operation amplifier.
6	LINP	Non-inverted input pin of general-purpose operation amplifier.
7	LOUT	ATT + equalizer output pin.
8	LSB	Capacitor and resistor connection pin comprising filters for bass and super-bass band.
9	LBASS2	Capacitor and resistor connection pin comprising filters for bass and super-bass band.
10	LBASS1	Capacitor and resistor connection pin comprising filters for bass and super-bass band.
11	LTRE	Capacitor and resistor connection pin comprising treble band filter.
12	LVRIN	Volume input pin.
13	LSELO	Input selector output pin.
14	L5	Input signal pin.
15	L4	Input signal pin.
16	L3	Input signal pin.
17	L2	Input signal pin.
18	L1	Input signal pin.
19	Vref	0.5 x VDD voltage generation block for analog ground.
20	R1	Input signal pin.
21	R2	Input signal pin.
22	R3	Input signal pin.
23	R4	Input signal pin.
24	R5	Input signal pin.
25	RSELO	Input selector output pin.
26	RVRIN	Volume input pin.
27	RTRE	Capacitor connection pin comprising treble band filter.
28	RBASS1	Capacitor and resistor connection pin comprising filter for bass and super-bass band.
29	RBASS2	Capacitor and resistor connection pin comprising filter for bass and super-bass band.
30	RSB	Capacitor and resistor connection pin comprising filter for bass and super-bass band.
31	ROUT	ATT + equalizer output pin.
32	RINP	Non inverted input pin of general-purpose operation amplifier.
33	RINM	Non inverted input pin of general purpose operation amplifier.
34	ROPOUT	Output pin of general-purpose operation amplifier.
35	VDD	Supply pin.
36	CL	Serial data and clock input pin for control.

■ AN22000A-W (IC601) : RF head amp.

1. Pin layout

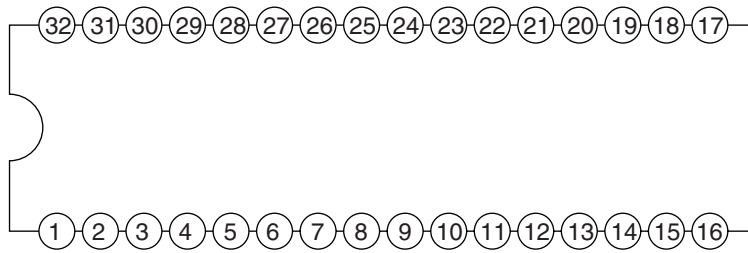

2. Block diagram

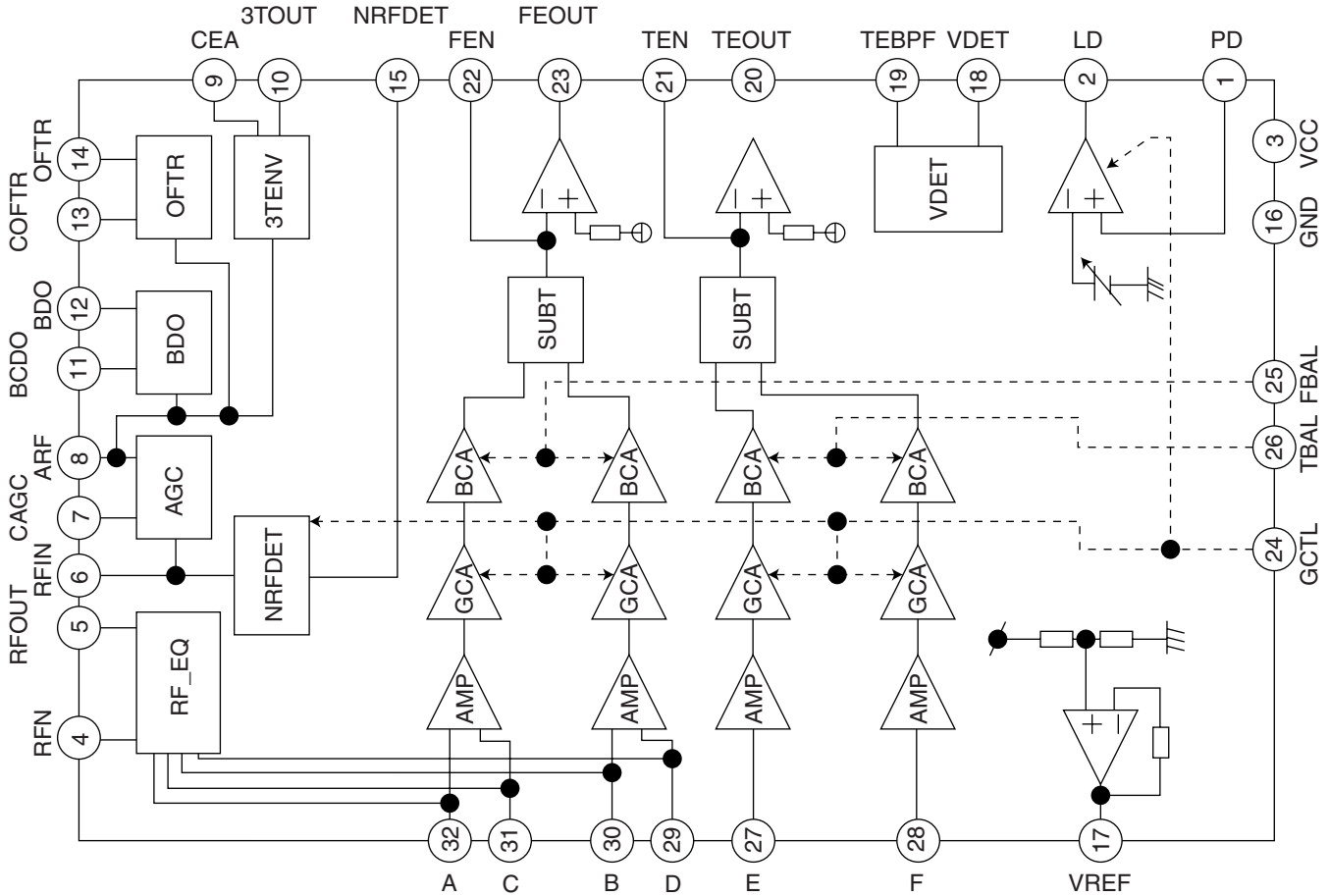

3. Pin function

Pin No.	Function	Pin No.	Function
1	APC amp input terminal.	17	VREF output terminal.
2	APC amp output terminal.	18	VDET output terminal.
3	Power supply.	19	VDET input terminal.
4	RF amp negative input terminal.	20	TE amp. output terminal.
5	RF amp output terminal.	21	TE amp. negative input terminal.
6	AGC input terminal.	22	FE amp. negative input terminal.
7	AGC loop filter capacitor connection terminal.	23	FE amp. output terminal.
8	AGC output terminal.	24	GCTL & APC terminal.
9	Capacitor connection terminal for HPF-amp.	25	FBAL control terminal.
10	3TENV output terminal.	26	TBAL control terminal.
11	Capacitor connection terminal for RF envelope detection.	27	Tracking signal input terminal 1.
12	BDO output terminal.	28	Tracking signal input terminal 2.
13	Capacitor connection terminal for RF envelope detection.	29	Focus signal input terminal 4.
14	OFTR output terminal.	30	Focus signal input terminal 3.
15	NRDET output terminal.	31	Focus signal input terminal 2.
16	Ground terminal.	32	Focus signal input terminal 1.

■ BA15218F-XE (IC611, IC904) : Dual operation amplifier

1. Pin layout

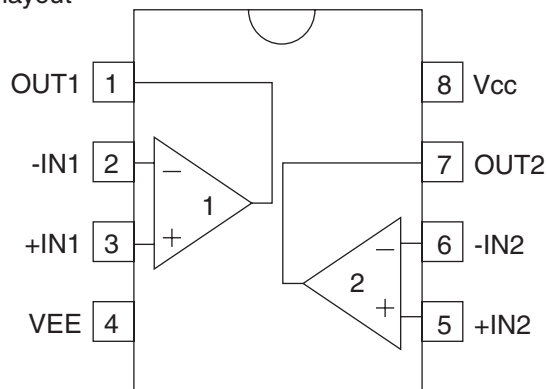

2. Block diagram

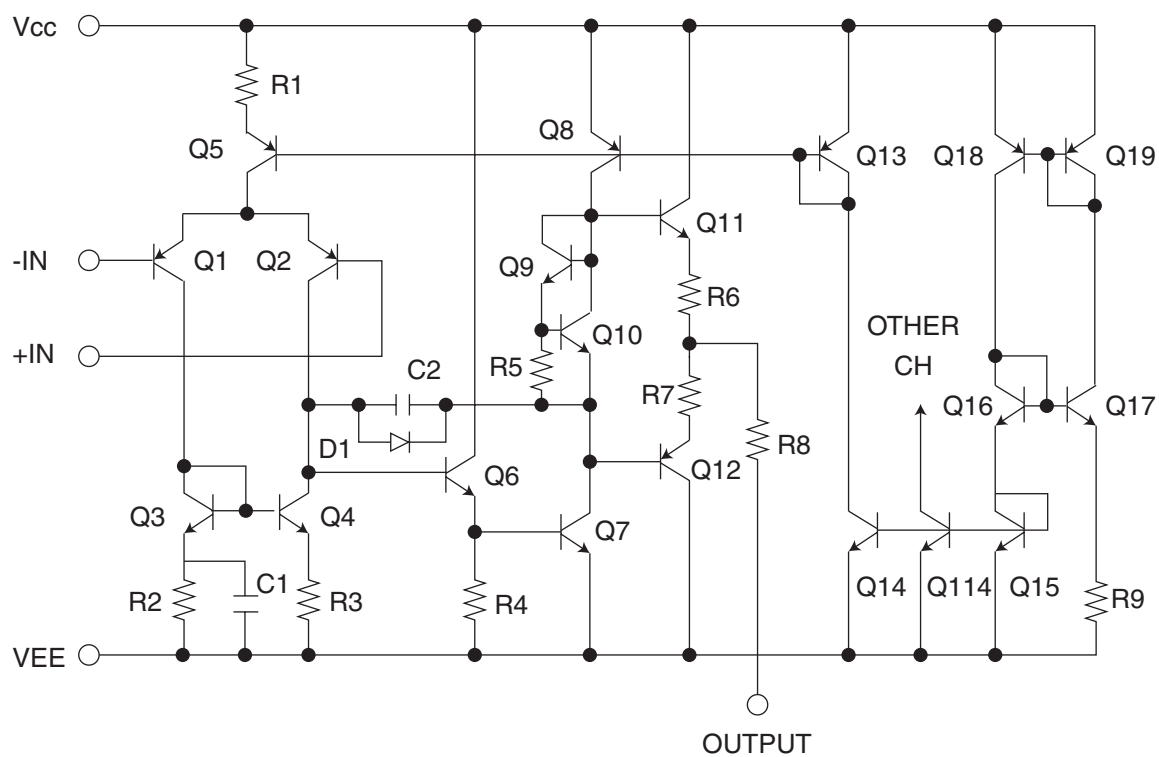

■ BU9253FS-X (IC612) : 1chip KARAOKE echo

1. Pin layout

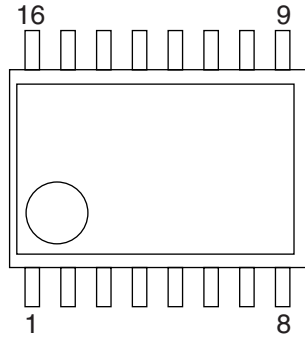

2. Block diagram

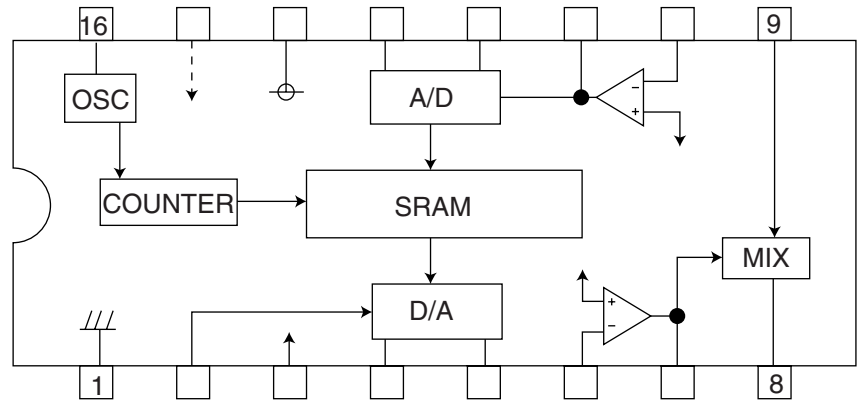

3. Pin functions

Pin No.	Symbol	Function
1	GND	Ground terminal.
2	ECHO VR	Echo level DC control terminal.
3	BIAS	Analog DC bias terminal.
4	DAINT IN	DA integral input terminal.
5	DAINT OUT	DA integral output terminal.
6	DALPF IN	DA LPF input terminal.
7	DALPF OUT	DA LPF output terminal.
8	MIX OUT	Mixing signal output terminal.
9	MIX IN	Mixing amp signal input terminal.
10	ADLPF IN	AD LPF input terminal.
11	ADLPF OUT	AD LPF output terminal.
12	ADINT OUT	AD integral output terminal.
13	ADINT IN	AD integral input terminal.
14	VCC	Vcc terminal.
15	MUTE	Mute control terminal.
16	CR	CR terminal for OSC.

## ■ L4909 (IC910) : Regulator

### 1. Pin layout

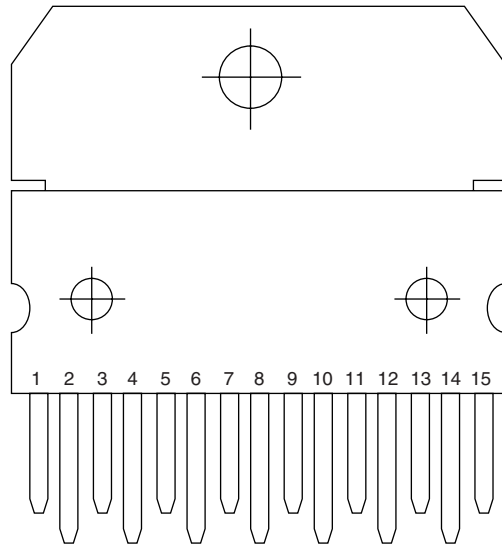

### 2. Block diagram

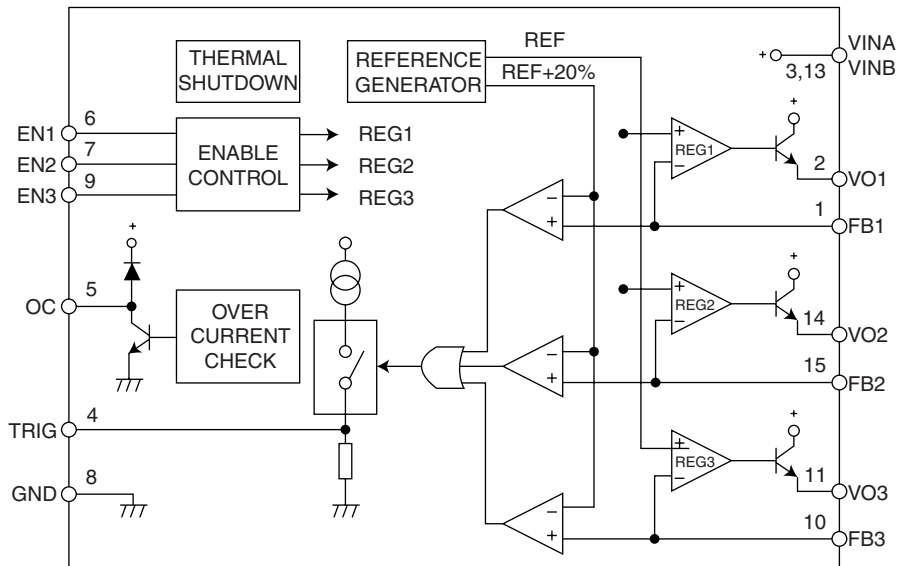

### 3. Pin functions

Pin No.	Symbol	Function
1	FB1	REG1 feedback voltage input
2	VO1	REG1 output voltage
3	VINA	Input DC supply voltage
4	TRIG	Trigger for external SCR (crowbar protection)
5	OC	Over current warning output
6	EN1	REG1 enable input
7	EN2	REG2 enable input
8	GND	Analog ground
9	EN3	REG3 enable input
10	FB3	REG3 feedback voltage input
11	VO3	REG3 output voltage
12	N.C.	Not connected
13	VINB	Input DC supply voltage
14	VO2	REG2 output voltage
15	FB2	REG2 feedback voltage input

■ LA6541-X (IC801) : Servo driver

1. Pin Layout & block diagram

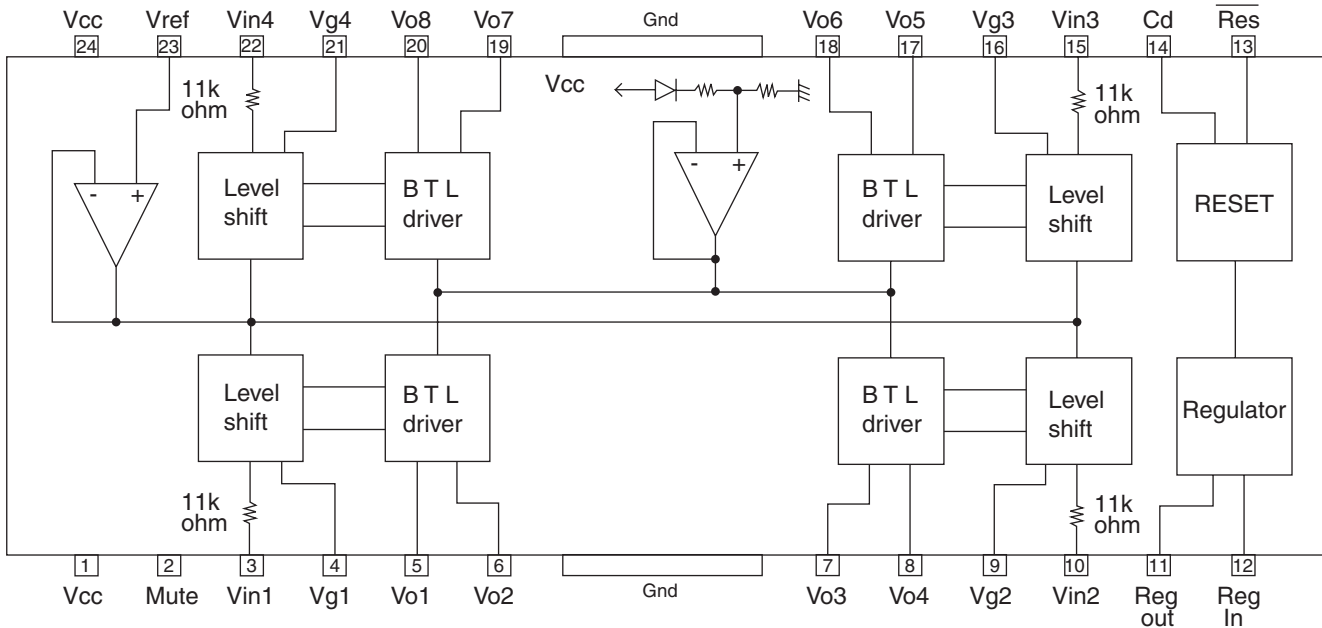

2. Pin function

Pin No.	Symbol	Function
1	Vcc	Power supply (Shorted to pin 24)
2	Mute	All BTL amplifier outputs ON/OFF
3	Vin1	BTL AMP 1 input pin
4	Vg1	BTL AMP 1 input pin (For gain adjustment)
5	Vo1	BTL AMP 1 input pin (Non inverting side)
6	Vo2	BTL AMP 1 input pin (Inverting side)
7	Vo3	BTL AMP 2 input pin (Inverting side)
8	Vo4	BTL AMP 2 input pin (Non inverting side)
9	Vg2	BTL AMP 2 input pin (For gain adjustment)
10	Vin2	BTL AMP 2 input pin
11	Reg Out	External transistor collector (PNP) connection. 5V power supply output
12	Reg In	External transistor (PNP) base connection
13	Res	Reset output
14	Cd	Reset output delay time setting (Capacitor connected externally)
15	Vin3	BTL AMP 3 input pin
16	Vg3	BTL AMP 3 input pin (For gain adjustment)
17	Vo5	BTL AMP 3 output pin (Non inverting side)
18	Vo6	BTL AMP 3 output pin (Inverting side)
19	Vo7	BTL AMP 4 output pin (Inverting side)
20	Vo8	BTL AMP 4 output pin (Non inverting side)
21	Vg4	BTL AMP 4 output pin (For gain adjustment)
22	Vin4	BTL AMP 4 output pin
23	Vref	Level shift circuit's reference voltage application
24	Vcc	Power supply (Shorted to pin 1)

■ TDA7294 (IC940, IC941) : Audio amp.

1. Pin layout

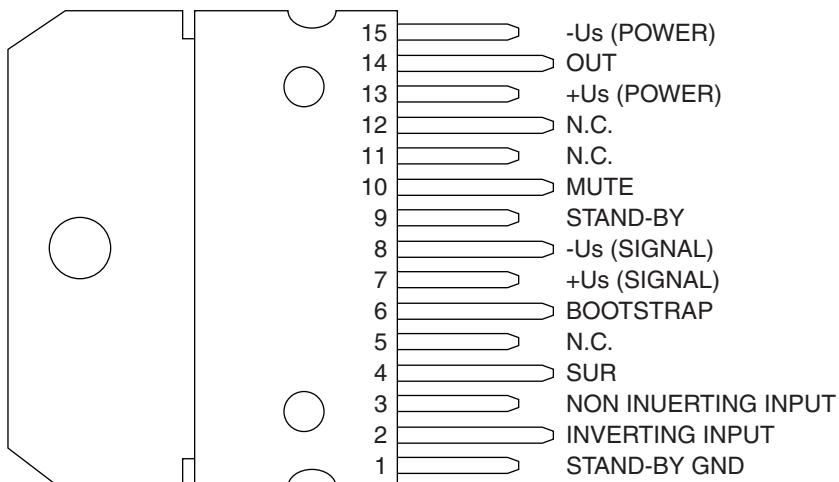

2. Block diagram

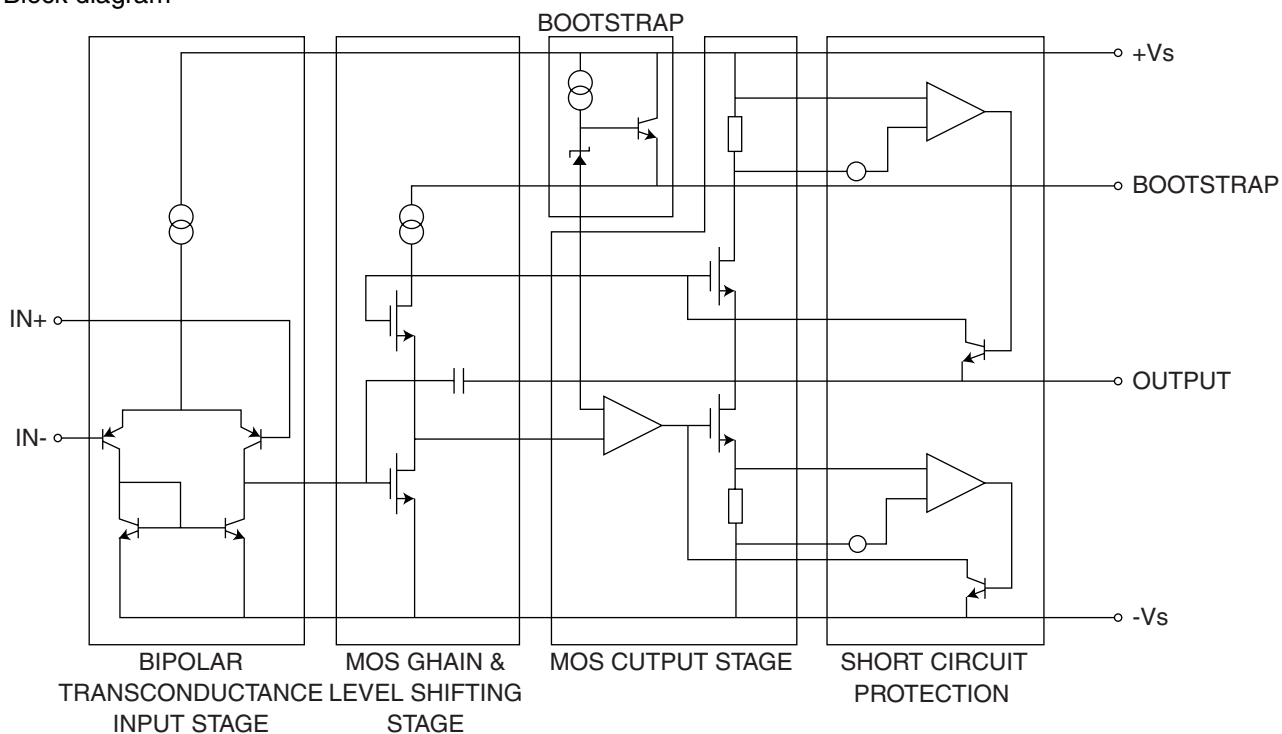

## ■ UPD780056GC-037 (IC937) : Micon

### 1. Pin layout

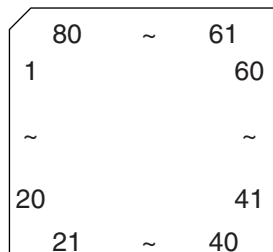

### 2. Pin functions

Pin No.	Symbol	I/O	Function
1	SAFETY0	I	Irregular voltage detection 0
2	-	-	Non connect
3	-	-	Non connect
4	-	-	Non connect
5	-	-	Non connect
6	-	-	Non connect
7	-	-	Non connect
8	MSTAT	I	UART receive
9	MCMND	O	UART transmit
10	-	-	Non connect
11	-	-	Non connect
12	_CDMRST	O	CD micon reset
13	_VCDRST	O	ESS micon reset
14	-	-	Non connect
15	-	-	Non connect
16	-	-	Non connect
17	SDATA	O	Serial data (Tuner PLL / Tape IC)
18	SCK	O	Serial clock (Tuner PLL / Tape IC)
19	KARAOKE	O	
20	ECHO	O	Trigger echo function
21	-	-	Non connect
22	F_CD	O	CD function
23	-	-	Non connect
24	_AHB1	O	Sub woofer amp AHB control
25	VOLCE	O	Volume chip enable
26	-	-	Non connect
27	-	-	Non connect
28	PBMUTE	O	Tape play mute
29	SMUTE	O	System mute
30	SPKMUTE	O	Speaker mute
31	_AHB	O	Active Hyper Bass On/Off
32	POUT	O	Power On/Off
33	-	-	Non connect
34	PROTR	O	Protector
35	MODEL1	I	MODEL 0 : P38 / P58 ; 1 : P78
36	MODEL2	I	MODEL2 0 : P38 ; 1 : P58
37	-	-	Non connect
38	-	-	Non connect
39	-	-	Non connect
40	LEDRV	O	Lite LED indicate reverse



## 2. Pin functions (2)

Pin No.	Symbol	I/O	Function
41	LED_REC	O	Lite LED indicate REC
42	LED_FR	O	Lite LED indicate Forward
43	STTA	O	Tape IC strobe
44	LCDAT	O	LCD data
45	LMODE	O	LCD data mode control
46	LCDCK	O	LCD clock
47	-	-	Non connect
48	HALL	I	Tape end detection
49	INH_	O	LCD driver inhibit
50	LCDCE	O	LCD driver chip enable
51	DIMCTL	O	LCD DIM control
52	VOLP	I	Volume plus
53	LEDCTL	O	Power standby LED control
54	BASM	I	Bass minus
55	VOLM	I	Volume minus
56	BASP	I	Bass plus
57	PERIOD	O	Tuner PLL strobe
58	F_TU	O	Tuner function ("H"=Tuner)
59	BU_P	O	Backup power detect ("H"=Backup)
60	-	-	Non connect
61	REM	I	Remote control input
62	-	-	Non connect
63	MPX	I	FM stereo detection ("L"=Stereo)
64	-	-	Non connect
65	BCTL	O	Switched 5V controller ("H"=5V off)
66	-	-	Non connect
67	-	-	Non connect
68	-	-	Non connect
69	-	-	Non connect
70	-	-	Non connect
71	-	-	Non connect
72	-	-	Non connect
73	-	-	Non connect
74	-	-	Non connect
75	-	-	Non connect
76	SAFETY1	I	Irregular voltage detection 1
77	TAPE0	I	Tape switch 0
78	TAPE1	I	Tape switch 1
79	KEY1	I	Unit key 1
80	KEY2	I	Unit key 0

■ NJU6433FG1 (IC934) : LCD driver

1. Pin layout

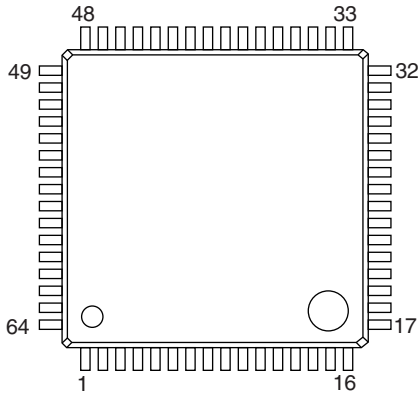

2. Pin function

Pin No.	Symbol	Function
1~50	SEG1~SEG50	Segment output terminal for LCD.
51,52	OSC1,OSC2	CR oscillating terminal.
53	VDD	Power supply terminal for inside.
54	Vss	GND level.
55	VLCD	Power supply terminal for LCD drive.
56	CE	Chip enable.
57	SCL	Serial data transmission clock terminal.
58	DATA	Serial data input terminal.
59	MODE	Mode-setting-signal input terminal.
60	INH	Display-off control signal input terminal.
61~44	COM4~COM1	Common output terminal for LCD.

3. Block diagram

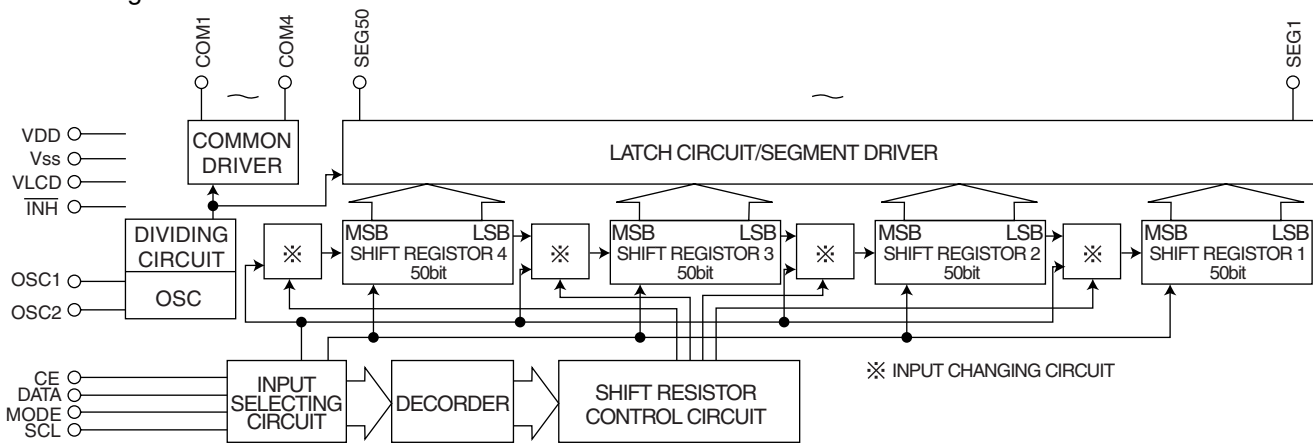

■ GP1U261X (IC933) : Receiver

1. Pin layout

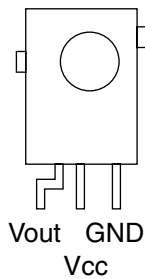

2. Block diagram

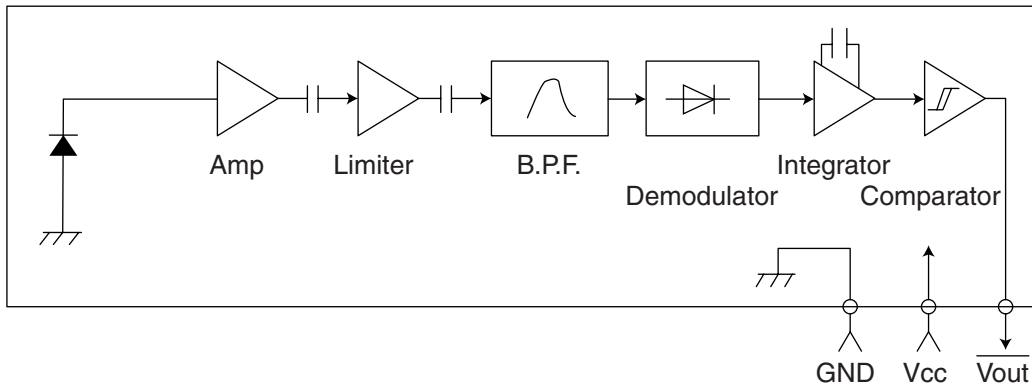

■ KIA7806API (IC932) : Regulator

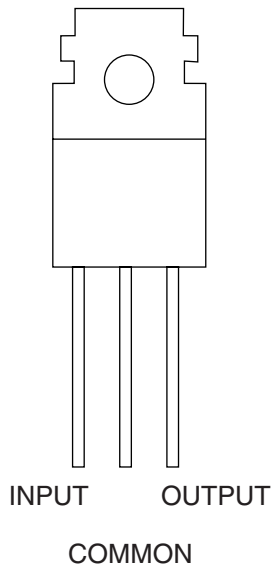

■ NJM4580E-W (IC652) : Ope amp.

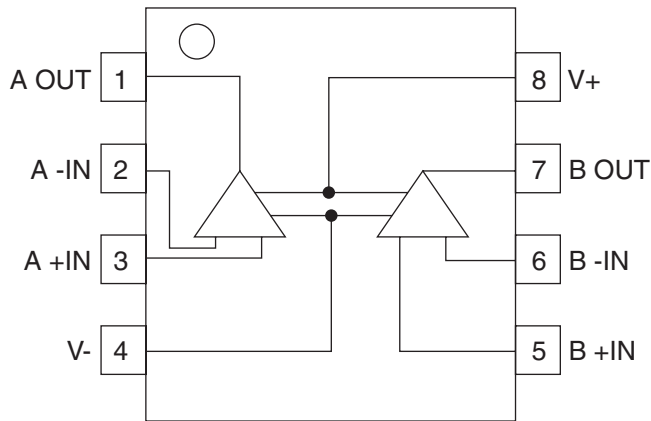

■ LB1641 (IC802) : DC motor driver

1. Pin layout

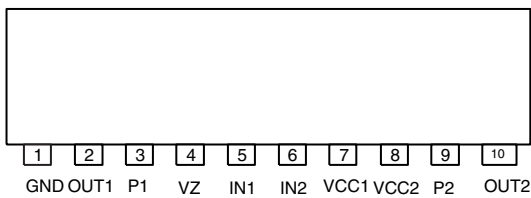

2. Pin function

Input		Output		Mode
IN1	IN2	OUT1	OUT2	
0	0	0	0	Brake
1	0	1	0	CLOCKWISE
0	1	0	1	COUNTER-CLOCKWISE
1	1	0	0	Brake



**VICTOR COMPANY OF JAPAN, LIMITED**  
AUDIO & COMMUNICATION BUSINESS DIVISION  
PERSONAL & MOBILE NETWORK BUSINESS UNIT. 10-1, 1 chome, Ohwatari-machi, Maebashi-city, 371-8543, Japan